

여명닛불



www.ymnipple.com

인사말

귀사의 무궁한 발전과 번창하심을 기원합니다.
평소 저희 제품을 애용해주신 고객 여러분께 진심으로
감사의말씀을 드립니다.
그동안의 풍부한 경험, 축적된 기술력을 바탕으로 규격품과 제작품을
기준으로 본 TOTAL CADALOGUE를 제작하게 되었습니다.
저희는 고객 여러분이 요구와 필요에 적극 대처하여 고객 여러분께서
만족하실 수 있는 제품을 항상 적기에 공급토록 혼신의 노력을 기울이
겠습니다.
미흡한점 있더라도 많은 지도편달바라며 귀사 발전을 다시 기원합니다.

여명닛볼 임직원 일동



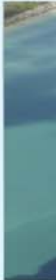

Brass Nipple



	Hex Nipple	YHN	12
	Reducing Nipple	YHRN	12
	Reducing Socket	YHRS	13
	Hex Socket	YHS	13
	Hex Plug	YHP	13
	Hex Bushing	YHB	14
	Male/Female Adapter	YHR	14
	Reducer	YHR	14
	Hose Nipple	YNHN	15
	Female Hose Nipple	YFHN	16
	Hose Elbow	YHE	16
	Hose Union	YHU	17
	Hose Union Y	YHY	17
	Hose Union T	YHT	17
	Female Tee	YST	18
	Female Elbow	YSL	18

	Female Cross	YCT	19
	Male/Female Elbow	YSEL	19
	Male Elbow	YMEL	19
	Grease Nipple A-Type	A-PT	20
	Grease Nipple B-Type	B-PT	20
	Grease Nipple C-Type	C-PT	20
	Grease Nipple PIN-Type	PIN	21
	Grease Nipple Button Head	BH	21
	Relief Fitting	YRF	21
	Oil Nipple	YON	22

Copper Tube Connector

	Sleeve	YRS	24
	Ring Nut	YRN	24
	Ring Male Connector	YRMC	25
	Ring Union	YRU	25
	Ring Union Elbow	YRUL	26
	Ring Union Tee	YRUT	26

	Ring Male Elbow	YRML	27		Male Connector	YBMC	36
	Ring Branch Tee	YRTA	27		Male Connector	SBMC	36
	Flare Nut : 고압용	YHFN	28		Male Elbow	BLM	37
	Flare Nut : 저압용	YLFN	28		Male Elbow	YBLM	37
	Flare Male Connector	YFM	28		Male Elbow	SBLM	37
	Flare Male Elbow	YFL	29		Straight Union	BU	38
	Flare Union	YFU	30		Straight Union	YBU	38
	Flare Union Elbow	YFUL	30		Straight Union	SBU	38
	Flare Union Tee	YFUT	30		Union Elbow	BL	39
Oil, Grease 배관 Nipple					Union Elbow	YBL	39
	Plug	PA	32		Union Elbow	SBL	39
	Sleeve	PB	32		Union Tee	BT	40
	Nipple	PD	32		Union Tee	YBT	40
	Elbow	PH	33		Union Tee	SBT	40
	Tee	PKD	33		Straight Bulkhead Union	BBU	41
Bite Type Tube Connector					Straight Bulkhead Union	YBBU	41
	Male Connector	BMC	36		Straight Bulkhead Union	SBBU	41

	Male Connector	BMCG	42
	Male Connector	BMCG	42

Hyd's Bite Type Tube Connector

	Male Branch Tee	BBTM	43
	Male Branch Tee	BBTM	43
	Male Run Tee	BRTM	44
	Male Run Tee	BRTM	44
	Female Connector	BFC	45
	Female Connector	BFC	45
	Gauge Connector	BGC	46
	Gauge Connector	BGC	46
	Nut	MBN	47
	Sleeve	MBS	47

Hyd's Hose Adaptor

	고압 HOSE용 연결 아답터	MFM	50
	고압 HOSE용 Elbow	MFL	51
	고압 HOSE용 45° Elbow	MFL	52

	고압 HOSE용 Union	MFU	52
	010 호스용 아답터(SE용)	010	53
	090 90° 호스용 아답터 (SE용)	090	53
	045 45° 호스용 아답터 (SE용)	045	53
	110 호스용 아답터(SF용)	110	54
	190 90° 호스용 아답터 (SF용)	190	54
	145 45° 호스용 아답터 (SF용)	145	54
	050 호스용 아답터(SE용)	050	55
	150 호스용 아답터(SE용)	150	55
	MCS-1	MCS-1	56
	MCS-2	MCS-2	56
	MPA-1	MPA-1	56
	MPA-2	MPA-2	57
	MSWC	MSWC	57
	MSWE	MSWE	57





Hyd's Pipe 배관용 Nipple

Socket Welding Fitting

	90° Elbow	MLW	60
	Tee	MTW	60
	45° Elbow	MLLW	61
	Union	MUW	61
	Full Coupling	MWFC	62
	Half Coupling	MWHC	62
	Reducing Coupling	MWRC	63
	Union	MUS	64
	90° Elbow	MSL	64
	45° Elbow	MSLL	64
	Street Elbow	MSEL	65
	Tee	MST	65
	Full Coupling	MFC	66
	Half Coupling	MHC	66
	Hex Nipple	MHN	67
	Reducing Nipple	MHRN	67
	Hex Socket	MHS	68

	Reducing Socket	MHRS	68
	Lench Plug	MLP	69
	Square Head Plug	MSP	69
	Male/Female Adapter Type A	MHR	69
	Hex Bushing	MHB	70
	Male/Female Adapter Type C	MHR	70

Pipe & Tube Clamp

	Fix clamp		72
	Hevy		74
	Standard		75
	Twin		75

One Touch Fitting & Hose

	PC Type	PC	78
	PL Type	PL	78
	PUC Type	PUC	79
	PUL Type	PUL	79
	PUT Type	PUT	79

One Touch Fitting & Hose



PT Type PT 80



PCF Type PCF 80



PLL Type PLL 81



PST Type PST 81



PW Type PW 82



PY Type PY 82



PWT Type PWT 82



PG Type PG 83



PZA Type PZA 83



PMM Type PMM 83

Speed control



Elbow Type NSE 84



Flat Type NSF 85



Hvu Type HVFF 85

Silencers



Plastic Type ST 86



SL 86



SM 86

Polyuretan Hose



Polyuretan Hose PU 87



Coil Hose Coupling UC 87

Nylon Tube



Nylon Tube N 88

Two Touch Fitting



CK Type CK 88



GCK Type GCK 89



FCK Type FCK 89

Two Touch Pe Nipple



Male Straight YCIN 91



Male Elbow YLIN 92



Male Branch Tee YTIN 93



Union Straight YUCIN 94



Union Tee YUTIN 94

Air Coupling

Ace Coupler

	코르크(CORK)·C 호스 접속용	PH	96
	코르크(CORK)·C 숫나사 접속용	PM	96
	코르크(CORK)·C 암나사 접속용	PF	96

Ace Coupler

	홀(HOLE)·S 호스 접속용	SH	97
	홀(HOLE)·S 숫나사 접속용	SM	97
	홀(HOLE)·S 암나사 접속용	SF	97

Nut Coupler

	코르크(CORK)·C 우레탄튜브 접속용	PN	98
	코르크(CORK)·C 우레탄튜브 접속용	SN	98
	Spring Type	SN-S	99
	Spring Type	PN-S	99

Oil (Water) Coupling

	TSP Coupler 플러그(PLUG)·P 숫나사 접속용	TPM	100
	TSP Coupler 플러그(PLUG)·P 암나사 접속용	TPF	100
	TSP Coupler SOCKET·S 숫나사 접속용	TSM	101
	TSP Coupler SOCKET·S 암나사 접속용	TSF	101
	SP Coupler 플러그(PLUG)·SP-P	P	102
	SP Coupler SOCKET·SP-S	S	102

Hyd's Coupling

	HSP Coupler 플러그(PLUG)·HP	HP	103
	HSP Coupler SOCKET·HS	HS	103

Ball Valve

	2-Way Ball Valve (Brass)		109
	Hyd's Ball Valve (Steel, Stain Steel)		109
	Stainless Ball Valves	1PC	110
	Stainless Ball Valves	1PC	110
	Stainless Ball Valves	2PC	110

YM NIPPLE

Brass Nipple

Hex Nipple
 Reducing Nipple
 Reducing Socket
 Socket
 Hex Plug
 Hex Bushing
 Male/Female Adapter
 Reducer
 Hose Nipple
 Female Hose Nipple
 Hose Elbow
 Hose Union
 Hose Union Y.T
 Female Tee
 Female Elbow
 Female Cross
 Male·Female Elbow
 Male Elbow
 Grease Nipple A-Type
 Grease Nipple B-Type
 Grease Nipple C-Type
 Grease Nipple Pin Type
 Grease Nipple Button Head
 Relief Fitting
 Oil Nipple



Hex Nipple

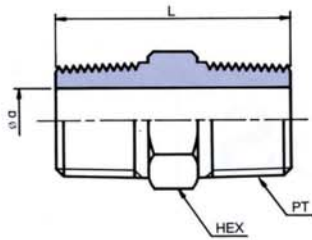

품 명	관용나사 (PT)	d	Hex	L
YHN 1/8	1/8	6	10	22
YHN 1/4	1/4	8	13.5	26
YHN 3/8	3/8	11	17	29
YHN 1/2	1/2	14	21	34
YHN 3/4	3/4	19	27	39
YHN 1	1	24	34	46
YHN 1 1/4	1 1/4	33	42	47
YHN 1 1/2	1 1/2	39	48	50
YHN 2	2	49	60	55

Reducing Nipple

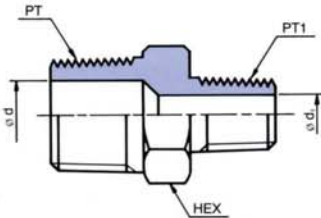

품 명	관용나사 (PT)	관용나사 (PT1)	d	d1	Hex	L
YHRN 1/4-1/8	1/4	1/8	8	6	13.5	24
YHRN 3/8-1/4	3/8	1/4	11	8	17	28
YHRN 1/2-1/4	1/2	1/4	14	8	21	31
YHRN 1/2-3/8	1/2	3/8	14	11	21	32
YHRN 3/4-1/2	3/4	1/2	19	14	27	37
YHRN 1 - 3/4	1	3/4	24	19	34	43
YHRN 1 1/4 - 1	1 1/4	1	33	24	42	47
YHRN 1 1/2 - 1 1/4	1 1/2	1 1/4	39	33	48	49
YHRN 2 - 1 1/2	2	1 1/2	49	39	60	53

■ 색은 제품입니다

Reducing Socket

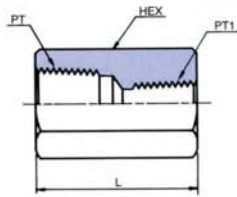

품 명	관용나사 (PT)	관용나사 (PT1)	Hex	L
YHRS 1/4-1/8	1/4	1/8	17	26
YHRS 3/8-1/4	3/8	1/4	21	30
YHRS 1/2-1/4	1/2	1/4	25.4	34
YHRS 1/2-3/8	1/2	3/8	25.4	34
YHRS 3/4-3/8	3/4	3/8	32	38
YHRS 3/4-1/2	3/4	1/2	32	39
YHRS 1 - 3/4	1	3/4	38	42

■ 색은 제작품입니다

Hex Socket

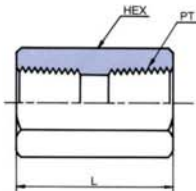

품 명	관용나사 (PT)	Hex	L
YHS 1/8	1/8	14	19
YHS 1/4	1/4	17	23
YHS 3/8	3/8	21	25
YHS 1/2	1/2	25.4	28
YHS 3/4	3/4	32	35
YHS 1	1	32	40

Hex Plug

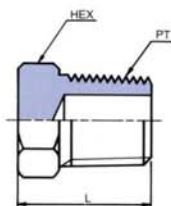

품 명	관용나사 (PT)	Hex	L
YHP 1/8	1/8	10	13
YHP 1/4	1/4	13.5	15
YHP 3/8	3/8	17	17
YHP 1/2	1/2	21	20
YHP 3/4	3/4	27	23
YHP 1	1	34	27

Hex Bushing

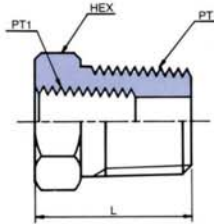

품명	관용나사 (PT)	관용나사 (PT1)	Hex	L
YHB 1/4-1/8	1/4	1/8	13.5	15
YHB 3/8-1/8	3/8	1/8	17	17
YHB 3/8-1/4	3/8	1/4	17	17
YHB 1/2-1/8	1/2	1/8	21	20
YHB 1/2-1/4	1/2	1/4	21	20
YHB 1/2-3/8	1/2	3/8	21	20
YHB 3/4-1/4	3/4	1/4	27	23
YHB 3/4-3/8	3/4	3/8	27	23
YHB 3/4-1/2	3/4	1/2	27	23
YHB 1-3/8	1	3/8	34	27
YHB 1-1/2	1	1/2	34	27
YHB 1-3/4	1	3/4	34	27

Male/Female Adapter

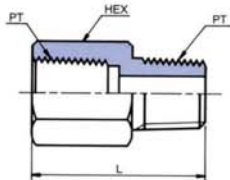

품명	관용나사 (PT)	Hex	L
YHR 1/8	1/8	13.5	22
YHR 1/4	1/4	17	27
YHR 3/8	3/8	21	30
YHR 1/2	1/2	25.4	34
YHR 3/4	3/4	32	40
YHR 1	1	40	42.5

Reducer

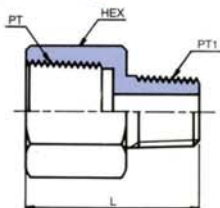

품명	관용나사 (PT)	관용나사 (PT1)	Hex	L
YHR 1/4-1/8	1/4	1/8	17	26
YHR 3/8-1/4	3/8	1/4	21	30
YHR 1/2-1/4	1/2	1/4	25.4	34
YHR 1/2-3/8	1/2	3/8	25.4	34
YHR 3/4-3/8	3/4	3/8	32	38
YHR 3/4-1/2	3/4	1/2	32	39
YHR 1-3/4	1	3/4	38	42

Hose Nipple

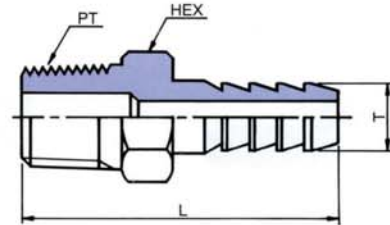

품 명	HOSE T	관용나사 (PT1)	Hex	L
YNHN 08 - 01	8	1/8	10	33
YNHN 09 - 01	9	1/8	10	33
YNHN 11 - 01	11	1/8	11	33
YNHN 13 - 01	13	1/8	13	34
YNHN 09 - 02	9	1/4	13.5	35
YNHN 11 - 02	11	1/4	13.5	35
YNHN 13 - 02	13	1/4	13.5	36
YNHN 09 - 03	9	3/8	17	39
YNHN 11 - 03	11	3/8	17	39
YNHN 13 - 03	13	3/8	17	41
YNHN 16 - 03	16	3/8	17	41
YNHN 09 - 04	9	1/2	21	43
YNHN 11 - 04	11	1/2	21	43
YNHN 13 - 04	13	1/2	21	44
YNHN 16 - 04	16	1/2	21	44
YNHN 20 - 04	20	1/2	21	44
YNHN 13 - 06	13	3/4	27	45
YNHN 16 - 06	16	3/4	27	49
YNHN 20 - 06	20	3/4	27	50
YNHN 25 - 06	25	3/4	27	52
YNHN 20 - 08	20	1	34	53
YNHN 25 - 08	25	1	34	56
YNHN 30 - 08	30	1	34	61
YNHN 33 - 10	33	1	42	61
YNHN 33 - 10	33	1 1/4	42	77
YNHN 38 - 12	38	1 1/4	48	77
YNHN 38 - 12	38	1 1/2	48	77.5
YNHN 50 - 16	50	2	60	100

■ 색은 제작품입니다

Female Hose Nipple

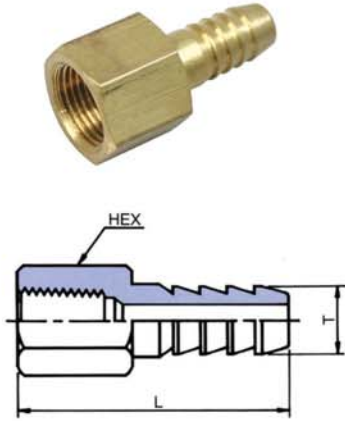

품 명	HOSE T	관용나사 (PT)	Hex	L
YFHN 08 - 01	8	1/8	14	28.5
YFHN 09 - 01	9	1/8	14	28.5
YFHN 09 - 02	9	1/4	17	30.5
YFHN 11 - 02	11	1/4	17	30.5
YFHN 09 - 03	9	3/8	21	32.5
YFHN 11 - 03	11	3/8	21	32.5
YFHN 13 - 03	13	3/8	21	34.5
YFHN 09 - 04	9	1/2	25.4	35
YFHN 11 - 04	11	1/2	25.4	35

색은 제작품입니다

Hose Elbow

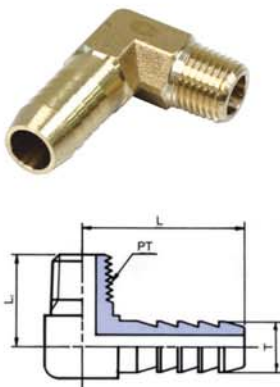

품 명	HOSE T	관용나사 (PT)	L	L1
YHE 8.0 - 01	8	1/8	33	19
YHE 9.0 - 01	9	1/8	33	19
YHE 8.0 - 02	8	1/4	34	24
YHE 9.0 - 02	9	1/4	34	24
YHE 11.0 - 02	11	1/4	36	25
YHE 13.0 - 02	13	1/4	36	25
YHE 9.0 - 0.3	9	3/8	35	27
YHE 11.0 - 0.3	11	3/8	36	27
YHE 13.0 - 0.3	13	3/8	36	27
YHE 16.0 - 03	16	3/8	37	27
YHE 9.0 - 0.4	9	1/2	37	32
YHE 11.0 - 0.4	11	1/2	38	32
YHE 13.0 - 0.4	13	1/2	38	32
YHE 16.0 - 0.4	16	1/2	39	32
YHE 20.0 - 0.4	20	1/2	43	34

Hose Union

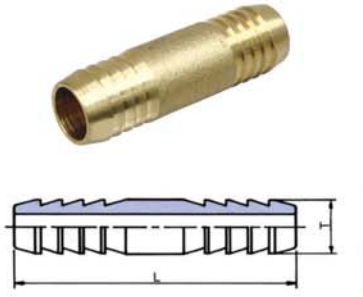

품명	HOSE T	L
YHU 05	5	32
YHU 06	6	31
YHU 08	8	47
YHU 09	9	48
YHU 11	11	52
YHU 13	13	60
YHU 16	16	64
YHU 20	20	68
YHU 25	25	70

Hose Union Y.T

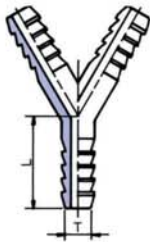

품명	HOSE T	L
YHY / YHT 06	6	27.5
YHY / YHT 08	8	30
YHY / YHT 09	6	32
YHY / YHT 11	11	32
YHY / YHT 13	13	35
YHY / YHT 16	16	35
YHT 20	20	38

색은 제작품입니다

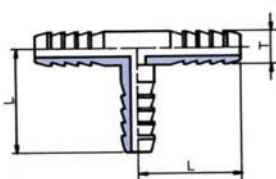

Female Tee

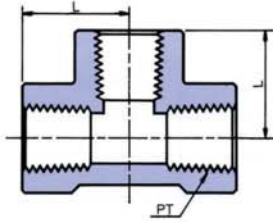

품 명	관용나사 (PT)	L
YST 1/8	1/8	16
YST 1/4	1/4	17
YST 3/8	3/8	22
YST 1/2	1/2	27
YST 3/4	3/4	30
YST 1	1	37
YST 1 1/4	1 1/4	44

Female Elbow

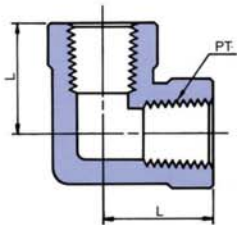

품 명	관용나사 (PT)	L
YSL 1/8	1/8	16
YSL 1/4	1/4	17
YSL 3/8	3/8	22
YSL 1/2	1/2	26
YSL 3/4	3/4	30
YSL 1	1	37
YSL 1 1/4	1 1/4	44
YSL 1 1/2	1 1/2	58

Female Cross

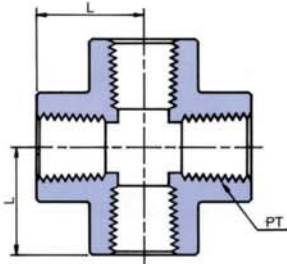

품 명	관용나사 (PT)	L
YCT 1/8	1/8	18
YCT 1/4	1/4	20
YCT 3/8	3/8	22
YCT 1/2	1/2	26
YCT 3/4	3/4	32
YCT 1	1	40

Male-Female Elbow

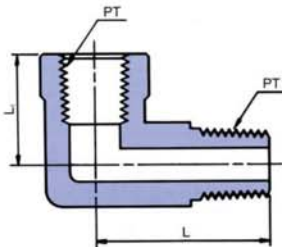

품 명	관용나사 (PT)	L1	L
YSEL 1/8	1/8	19	8.5
YSEL 1/4	1/4	20	13
YSEL 3/8	3/8	20	31
YSEL 1/2	1/2	22	33
YSEL 3/4	3/4	22	38
YSEL 1	1	24	40

※이형인 경우는 주문에 의한 생산

Male Elbow

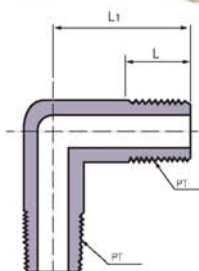

품 명	관용나사 (PT)	L1	L
YMEL 1/8	1/8	19.0	8.0
YMEL 1/4	1/4	24.5	10.0
YMEL 3/8	3/8	25.5	12.0
YMEL 1/2	1/2	33.0	14.5

Grease Nipple A-Type

(BRASS, STEEL, STAINLESS)

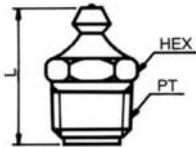

품 명	관용나사 (PT)	Hex	L
A-PT 1/8	1/8	10	17
A-PT 1/4	1/4	13.5	25
A-PT 3/8	3/8	17	23
A-PT 1/2	1/2	22	28
A-M6 x 0.75P	M6 x 0.75P	7	13
A-M6 x 1.0P	M6 x 1.0P	7	13

Grease Nipple B-Type

(BRASS, STEEL, STAINLESS)

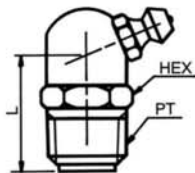

품 명	관용나사 (PT)	Hex	L
B-PT 1/8	1/8	10	12
B-PT 1/4	1/4	13.5	19
B-PT 3/8	3/8	17	22
B-PT 1/2	1/2	22	27
B-M6 x 0.75P	M6 x 0.75P	7	11
B-M6 x 1.0P	M6 x 1.0P	7	11

Grease Nipple C-Type

(BRASS, STEEL, STAINLESS)

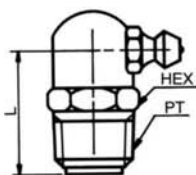

품 명	관용나사 (PT)	Hex	L
C-PT 1/8	1/8	10	12
C-PT 1/4	1/4	13.5	19
C-PT 3/8	3/8	17	22
C-PT 1/2	1/2	22	27
C-M6 x 0.75P	M6 x 0.75P	7	11
C-M6 x 1.0P	M6 x 1.0P	7	11

Grease Nipple Pin Type

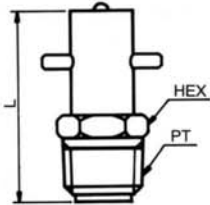

(BRASS, STAINLESS)

품 명	관용나사 (PT)	L1	L
PIN 1/8	1/8	10	27
PIN 1/4	1/4	13.5	30
PIN 3/8	3/8	17	30

Grease Nipple Button Head

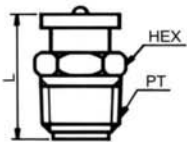

(BRASS, STAINLESS)

품 명	관용나사 (PT)	L1	L
BH 1/8	1/8	17	18
BH 1/4	1/4	17	21
BH 3/8	3/8	19	22

Relief Fitting

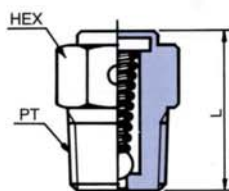

(BRASS)

품 명	관용나사 (PT)	Hex	L
YRF 1/8	1/8	10	15
YRF 1/4	1/4	13.5	18

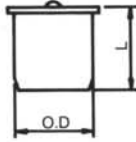
Oil Nipple

(BRASS)

품명	관용 Tube (O.D)	L
YON 1/4	M 4.8	5.8
YON 5/16	M 6.4	7.3
YON 3/8	M 9.5	9
YON 1/2	M 12.7	9.5

YMNIPPLE

Copper Tube Connector

Sleeve
Ring Nut
Ring Male Connector
Ring Union
Ring Union Elbow
Ring Union Tee
Ring Male Elbow
Ring Branch Tee
Flare Unit
Flare Nut
Flare Male Connector
Flare Male Elbow
Flare Union
Flare Union Elbow
Flare Union Tee



Sleeve

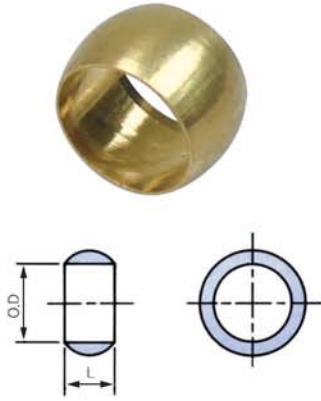

품 명	적용관 Tube O.D(mm)	L
YRS 04	4	5
YRS 06	6	7
YRS 08	8	7.5
YRS 10	10	8
YRS 12	12	9.5
YRS 3/16	4.8	6
YRS 1/4	6.35	7
YRS 5/16	4.8	7.5
YRS 3/8	9.52	7.5
YRS 1/2	12.7	9.5
YRS 5/8	15.88	10
YRS 3/4	19.05	12

Ring Nut

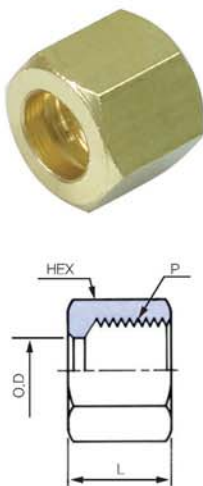

품 명	적용관 Tube O.D(mm)	P (inch)	Hex (mm)	L (mm)
YRN 06	6	7/16 x 24	18	12
YRN 08	8	1/2 x x 24	15	13
YRN 10	10	M14 x 1.0P	17	14
YRN 12	12	11/16 x 20	21	16.5
YRN 3/16	4.76	3/8 x 24	11	10
YRN 1/4	6.35	7/16 x 24	13	12
YRN 3/8	9.52	17/32 x v	16	14
YRN 1/2	12.70	11/16 x 20	21	16.5
YRN 5/8	15.88	M22 x 1.5P	25.4	18
YRN 3/4	19.05	1 x 18	30	21

Ring Male Connector

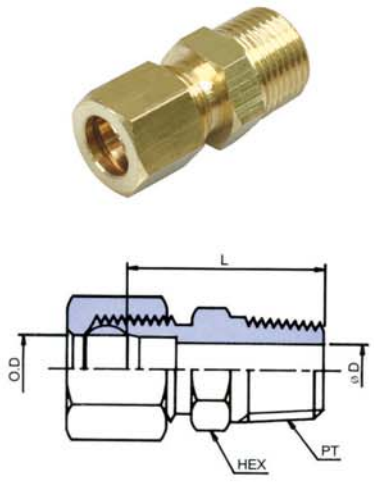

품 명	적용관 Tube O.D(mm)	관용나사 PT (inch)	Hex (mm)	D (mm)	L (mm)
YRMC 06-1/8	6	1/8	11	4.2	21
YRMC 06-1/4	6	1/4	13.5	4.2	23
YRMC 06-3/8	6	3/8	17	4.2	25
YRMC 06-1/2	6	1/2	21	4.2	29
YRMC 08-1/8	8	1/8	12.7	6.2	22
YRMC 08-1/4	8	1/4	13.5	6.2	24
YRMC 08-3/8	8	3/8	17	6.2	27
YRMC 08-1/2	8	1/2	21	6.2	30
YRMC 10-1/4	10	1/4	14	8.2	25
YRMC 10-3/8	10	3/8	17	8.2	28
YRMC 10-1/2	10	1/2	21	8.2	31
YRMC 12-3/8	12	3/8	18	10.2	29
YRMC 12-1/2	12	1/2	21	10.2	32
YRMC 3/16-1/8	4.76	1/8	10	2.96	20
YRMC 1/4-1/8	6.35	1/8	11	4.55	21
YRMC 1/4-1/4	6.35	1/4	13.5	4.55	23
YRMC 1/4-3/8	6.35	3/8	17	4.55	25
YRMC 1/4-1/2	6.35	1/2	21	4.55	29
YRMC 3/8-1/4	9.52	1/4	13.5	7.72	25
YRMC 3/8-3/8	9.52	3/8	17	7.72	28
YRMC 3/8-1/2	9.52	1/2	21	7.72	31
YRMC 1/2-1/4	12.70	1/4	18	10.90	26
YRMC 1/2-3/8	12.70	3/8	18	10.90	29
YRMC 1/2-1/2	12.70	1/2	21	10.90	32
YRMC 5/8-1/2	15.88	1/2	22	14.08	32
YRMC 3/4-1/2	19.05	1/2	25.4	17.25	34
YRMC 3/4-3/4	19.05	3/4	27	17.25	36

■ 색은 제작품입니다

Ring Union

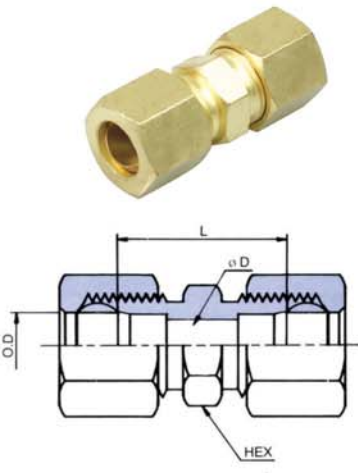

품 명	적용관 Tube O.D	Hex	D	L
YRU 06	6	11	4.2	20
YRU 08	8	12.7	6.2	22
YRU 10	10	14	8.2	24
YRU 12	12	18	10.2	27
YRU 3/16	4.76	10	2.96	20
YRU 1/4	6.35	11	4.55	20
YRU 3/8	9.52	13.5	7.72	24
YRU 1/2	12.70	18	10.9	27
YRU 5/8	15.88	22	14.08	29
YRU 3/4	19.05	25.4	17.25	32

■ 색은 제작품입니다

Ring Union Elbow

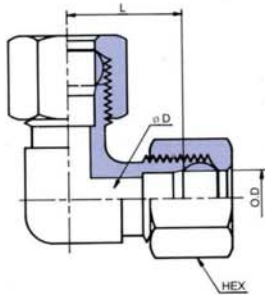

품명	적용관 Tube O.D	D	L
YRUL 06	6	4.2	14
YRUL 08	8	6.2	18
YRUL 10	10	8.2	18
YRUL 12	12	10.2	22
YRUL 3/16	4.76	2.96	13
YRUL 1/4	6.35	2.96	14
YRUL 3/8	9.52	7.72	18
YRUL 1/2	12.70	10.90	22
YRUL 5/8	15.88	14.08	28
YRUL 3/4	19.05	17.25	30

■ 색은 제작품입니다

Ring Union Tee

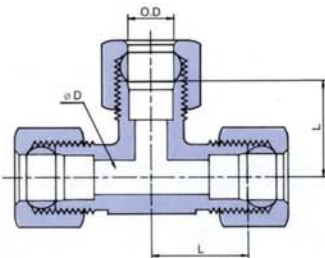

품명	적용관 Tube O.D	D	L
YRUT 06	6	4.2	14
YRUT 08	8	6.2	18
YRUT 10	10	8.2	18
YRUT 12	12	10.2	22
YRUT 3/16	4.76	2.96	13
YRUT 1/4	6.35	4.55	14
YRUT 3/8	9.52	7.72	18
YRUT 1/2	12.70	10.90	22
YRUT 5/8	15.88	14.08	28
YRUT 3/4	19.05	17.25	30

■ 색은 제작품입니다

Ring Male Elbow

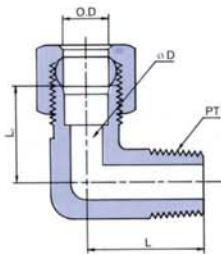

품 명	적용관 Tube O.D	관용나사 PT	D	L1	L
YRML 06-1/8	6	1/8	4.2	14	18
YRML 06-1/4	6	1/4	4.2	14	21
YRML 08-1/8	8	1/8	6.2	18	18
YRML 08-1/4	8	1/4	6.2	18	21
YRML 08-3/8	8	3/8	6.2	18	24
YRML 10-1/4	10	1/4	8.2	18	21
YRML 10-3/8	10	3/8	8.2	18	24
YRML 12-3/8	12	3/8	10.2	22	24
YRML 12-1/2	12	1/2	10.2	22	24
YRML 3/16-1/8	4.76	1/8	4.55	14	18
YRML 1/4-1/8	6.35	1/8	17.25	30	35
YRML 1/4-1/4	6.35	1/4	4.55	14	21
YRML 1/4-3/8	6.35	3/8	4.55	14	24
YRML 3/8-1/4	9.52	1/4	7.72	18	21
YRML 3/8-3/8	9.52	3/8	7.72	18	24
YRML 1/2-3/8	12.70	3/8	10.90	22	24
YRML 1/2-1/2	12.70	1/2	10.90	22	34
YRML 5/8-1/2	15.88	1/2	14.08	28	34
YRML 3/4-1/2	19.05	1/2	14.08	30	35
YRML 3/4-3/4	19.05	3/4	17.25	30	35

색은 제품입니다

Ring Branch Tee

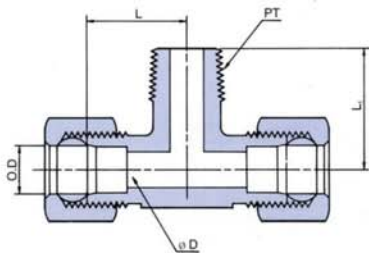

품 명	적용관 Tube O.D	관용나사 PT	D	L	L1
YRTA 06-1/8	6	1/8	4.2	14	18
YRTA 06-1/4	6	1/4	4.2	14	21
YRTA 08-1/8	8	1/8	6.2	18	18
YRTA 08-1/4	8	1/4	6.2	18	21
YRTA 08-3/8	8	3/8	6.2	18	24
YRTA 10-1/4	10	1/4	8.2	18	21
YRTA 10-3/8	10	3/8	8.2	18	24
YRTA 12-3/8	12	3/8	10.2	22	24
YRTA 1/4-1/8	6.35	1/8	4.55	14	18
YRTA 1/4-1/4	6.35	1/4	4.55	14	21
YRTA 1/4-3/8	6.35	3/8	4.55	14	24
YRTA 3/8-1/4	9.52	1/4	7.72	18	21
YRTA 3/8-3/8	9.52	3/8	7.72	18	24
YRTA 1/2-3/8	12.70	3/8	10.90	22	24
YRTA 1/2-1/2	12.70	1/2	10.90	22	34
YRTA 5/8-1/2	15.88	1/2	14.08	28	34
YRTA 3/4-3/4	19.05	3/4	17.25	30	35

색은 제품입니다

Flare Nut : 고압용

(Brass)

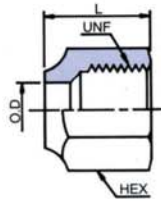

품 명	적용관(Tube)O.D		UNF	Hex	L
	(inch)	(mm)			
YHFN 1/4	1/4	6.35	7/16 x 20	16	13
YHFN 5/16	5/16	8	1/2 x 20	19	17
YHFN 3/8	3/8	9.52	5/8 x 18	21	17
YHFN 1/2	1/2	12.7	3/4 x 16	25.4	21
YHFN 5/8	5/8	15.88	7/8 x 14	28	21

Flare Nut : 저압용

(Brass)

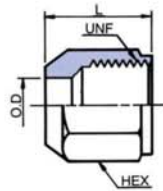

품 명	적용관(Tube)O.D		UNF	Hex	L
	(inch)	(mm)			
YLFN 3/16	3/16	4.75	3/8 x 24	13	14
YLFN 1/4	1/4	6.35	7/16 x 20	14	16
YLFN 5/16	5/16	8	1/2 x 20	15	17
YLFN 3/8	3/8	9.52	5/8 x 18	19	17
YLFN 1/2	1/2	12.70	3/4 x 16	22	21
YLFN 5/8	5/8	15.88	7/8 x 14	25.4	23
YLFN 3/4	3/4	19.05	1 1/16 x 14	32	28

Flare Male Connector

(Brass)

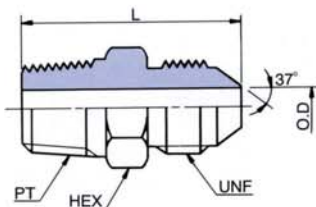

품 명	적용관 Tube(O.D)	관용나사 PT	UNF	Hex	L
YFM 3/16 X 1/8	3/16	1/8	3/8 X 24	10	26
YFM 1/4 X 1/8	1/4	1/8	7/16 X 20	11	27
YFM 1/4 X 1/4	1/4	1/4	7/16 X 20	13.5	29
YFM 1/4 X 3/8	1/4	3/8	7/16 X 20	17	31
YFM 1/4 X 1/2	1/4	1/2	7/16 X 20	21	33
YFM 5/16 X 1/8	5/16	1/8	1/2 X 20	12.7	29
YFM 5/16 X 1/4	5/16	1/4	1/2 X 20	13.5	30
YFM 5/16 X 3/8	5/16	3/8	1/2 X 20	17	31
YFM 5/16 X 1/2	5/16	1/2	1/2 X 20	21	34
YFM 3/8 X 1/4	3/8	1/4	5/8 X 18	17	33
YFM 3/8 X 3/8	3/8	3/8	5/8 X 18	17	34
YFM 3/8 X 1/2	3/8	1/2	5/8 X 18	21	35
YFM 1/2 X 1/4	1/2	1/4	3/4 X 16	19	36
YFM 1/2 X 3/8	1/2	3/8	3/4 X 16	19	35
YFM 1/2 X 1/2	1/2	1/2	3/4 X 17	21	38
YFM 5/8 X 3/8	5/8	3/8	7/8 X 14	22	38
YFM 5/8 X 1/2	5/8	1/2	7/8 X 14	22	38
YFM 5/8 X 3/4	5/8	3/4	7/8 X 14	27	42
YFM 3/4 X 1/2	3/4	1/2	1 1/16 X 14	27	42
YFM 3/4 X 3/4	3/4	3/4	1 1/16 X 14	27	42

Flare Male Elbow

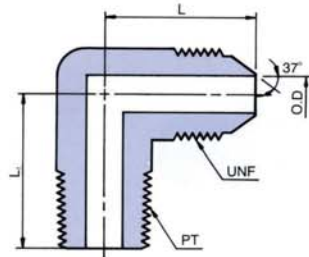

(Brass)

품 명	적용관 Tube(O.D)	관용나사 PT	UNF	Hex	L
YFL 3/16-1/8	3/16	1/8	3/8 X 24	18	19
YFL 1/4-1/8	1/4	1/8	7/16 X 20	18	19
YFL 1/4-1/4	1/4	1/4	7/16 X 20	23	23
YFL 5/16-1/8	5/16	1/8	1/2 X 20	23	23
YFL 5/16-1/4	5/16	1/4	1/2 X 20	23	23
YFL 5/16-3/8	5/16	3/8	1/2 X 20	24	25
YFL 3/8-1/4	3/8	1/4	5/8 X 18	24	26
YFL 3/8-3/8	3/8	3/8	5/8 X 18	26	26
YFL 3/8-1/2	3/8	1/2	5/8 X 18	34	34
YFL 1/2-1/4	1/2	1/4	3/4 X 16	28	28
YFL 1/2-3/8	1/2	3/8	3/4 X 16	30	30
YFL 1/2-1/2	1/2	1/2	3/4 X 16	33	33
YFL 5/8-3/8	5/8	3/8	3/4 X 14	33	34
YFL 5/8-1/2	5/8	1/2	3/4 X 14	35	35
YFL 3/4-1/2	3/4	1/2	1 1/16 X 14	37	42
YFL 3/4-3/4	3/4	3/4	1 1/16 X 14	42	42

Flare Union

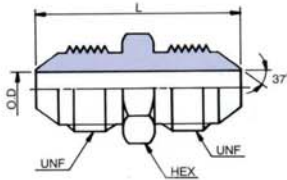

(Brass)

품 명	적용관 Tube(O.D)	UNF	Hex	L
YFU 3/16	3/16	3/8 x 24	10	27
YFU 1/4	1/4	7/16 x 20	11	30
YFU 5/16	5/16	1/2 x 20	13	32
YFU 3/8	3/8	5/8 x 18	16	35
YFU 1/2	1/2	3/4 x 16	19	38
YFU 5/8	5/8	7/8 x 14	22	45
YFU 3/4	3/4	1 1/16 x 14	27	50

Flare Union Elbow

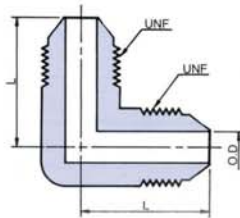

(Brass)

품 명	적용관 Tube(O.D)	UNF	L
YFUL 1/4	1/4	7/16 x 20	23
YFUL 5/16	5/16	1/2 x 20	23
YFUL 3/8	3/8	5/8 x 18	26
YFUL 1/2	1/2	3/4 x 16	33
YFUL 5/8	5/8	7/8 x 14	35
YFUL 3/4	3/4	1 1/16 x 14	42

Flare Union Tee

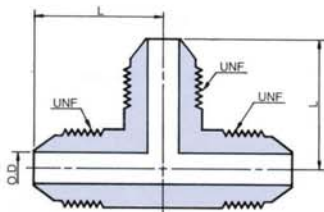

(Brass)

품 명	적용관 Tube(O.D)	UNF	L
YFUT 1/4	1/4	7/16 x 20	23
YFUT 5/16	5/16	1/2 x 20	23
YFUT 3/8	3/8	5/8 x 18	26
YFUT 1/2	1/2	3/4 x 16	33
YFUT 5/8	5/8	7/8 x 14	35
YFUT 3/4	3/4	1 1/16 x 14	42

Oil Grease 배관 Nipple

Plug
Sleeve
Nipple
Elbow
Tee



Plug

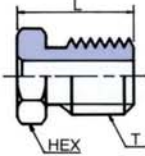

품 명	PT	L	T	Hex
PA 4	ø 4	12	M 8 x 1.0	8
PA 6	ø 6	12.5	M 10 x 1.0	10
PA 8	ø 8	14	M 14 x 1.5	14
PA 10	ø 10	15	M 16 x 1.5	17

색은 제작용입니다

Sleeve

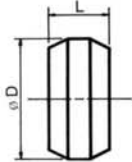

품 명	PT	ød	L
PB 4	ø 4	6	4.5
PB 6	ø 6	8	4.5
PB 8	ø 8	10	7
PB 10	ø 10	12	8

Nipple

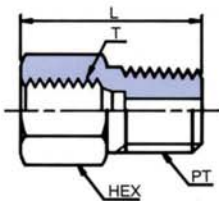

품 명	PT	L	T	PT	Hex
PD 4	ø 4	18	M 8 x 1.0	1/8	10
PD 6	ø 6	18	M 10 x 1.0	1/8	12

Elbow

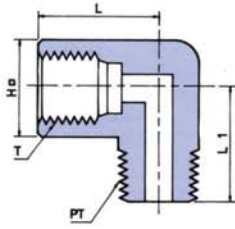

품 명	PT	T	PT	H	L1	L
PH 4	ø 4	M 8 x 1.0P	1/8	10	18	13
PH 6	ø 6	M 10 x 1.0P	1/8	12	20	14

Tee

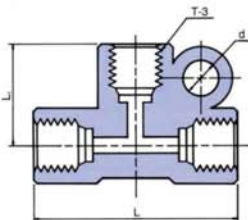

품 명	PT	L	L1	ød	T
PKD 4	ø 4	28	14	6.5	M 8 x 1.0
PKD 6	ø 6	30	15	6.5	M 10 x 1.0
PKD 8	ø 8	40	20	6.5	M 14 x 1.5
PKD 10	ø 10	45	22.5	6.5	M 16 x 1.5

색은 제작용입니다

YM NIPPLE

Bite Type Tube Connector

Steel, Stainless Steel, Brass

Male Connector
 Male Elbow
 Straight Union
 Union Elbow
 Union Tee
 Straight Bulkhead Union
 Male Connector
 Male Branch Tee
 Male Run Tee
 Female Connector
 Gauge Connector
 Nut
 Sleeve



Male Connector



(Brass, Stainless)

품명	Tube O.D		(PT) T	d	Basic gauge Length a	Width across flat		t	φ	Approx. L
	D					H1	H			
BMC04 - 01R		4	1/8	2.5	3.97	12	12	6	22	25.5
BMC06 - 01R		6	1/8	4	3.97	14	14	7	28	34.5
BMC06 - 02R		6	1/4	4	6.01	14	14	7	33	37.5
BMC08 - 01R		8	1/8	4	3.97	17	17	7	29	35.5
BMC08 - 02R		8	1/4	6	6.01	17	17	7	33	37.5
BMC10 - 02R		10	1/4	7	6.01	17	19	7	33	38.5
BMC10 - 03R		10	3/8	8	6.35	19	19	7	34	39
BMC10 - 04R		10	1/2	8	8.16	22	19	7	39	42.5
BMC12 - 02R		12	1/4	7	6.01	19	22	7	33	38.5
BMC12 - 03R		12	3/8	9	6.35	19	22	7	34	39
BMC12 - 04R		12	1/2	10	8.16	22	22	7	39	42.5
BMC15 - 03R		15	3/8	9	6.35	24	27	7.5	37	43
BMC15 - 04R		15	1/2	12	8.16	24	27	7.5	41	45.5
BMC16 - 03R		16	3/8	9	6.35	27	30	7.5	37	43
BMC16 - 04R		16	1/2	12	8.16	27	30	7.5	41	45.5
BMC18 - 03R		18	3/8	9	6.35	27	30	8	37	43
BMC18 - 04R		18	1/2	12	8.16	27	32	8	41	45.5
BMC20 - 04R		20	1/2	12	8.16	30	36	8	43	47.5
BMC20 - 06R		20	3/4	16	9.53	30	36	8	45	48
BMC22 - 04R		22	1/2	12	8.16	32	36	9	43	47.5
BMC22 - 06R		22	3/4	16	9.53	32	36	9	45	48
BMC25 - 06R		25	3/4	16	9.53	36	41	10	46	50
BMC25 - 08R		25	1	20	10.39	36	41	10	49	52
BMC28 - 06R		28	3/4	16	9.53	41	46	10	48	52.5
BMC28 - 08R		28	1	22	10.39	41	46	10	51	54.5
BMC30 - 08R		30	1	22	10.39	41	46	10	51	55
BMC30 - 10R		30	1 1/4	25	12.70	46	46	10	55	57
BMC32 - 10R		32	1 1/4	26	12.70	46	50	11	55	57
BMC35 - 10R		35	1 1/4	28	12.70	46	55	11	55	60
BMC38 - 12R		38	1 1/2	32	12.70	50	60	12	57	64
BMC40 - 12R		40	1 1/2	32	12.70	55	60	12	62	69
BMC42 - 12R		42	1 1/2	34	12.70	55	60	12	62	69
BMC50 - 16R		50	2	40	15.88	65	75	12	71	76.5
BMC81 - 01R	1/8	10.5	1/8	4	3.97	17	19	7	29	36.8
BMC81 - 02R	1/8	10.5	1/4	7	6.01	17	19	7	33	38.5
BMC82 - 02R	1/4	13.8	1/4	7	6.01	22	24	7.5	36	42
BMC82 - 03R	1/4	13.8	3/8	9	6.35	22	24	7.5	37	42.5
BMC83 - 03R	3/8	17.3	3/8	9	6.35	27	32	8	37	43
BMC83 - 04R	3/8	17.3	1/2	12	8.16	27	32	8	41	45.5
BMC84 - 04R	1/2	21.7	1/2	12	8.16	32	36	9	43	47.5
BMC84 - 06R	1/2	21.7	3/4	16	9.53	32	36	9	45	48
BMC85 - 06R	3/4	27.2	3/4	16	9.53	41	46	10	48	52.5
BMC85 - 08R	3/4	27.2	1	22	10.39	41	46	10	51	54.5
BMC86 - 08R	1	34.0	1	22	10.39	46	55	11	52	59
BMC86 - 10R	1	34.0	1 1/4	28	12.70	46	55	11	55	60
BMC87 - 10R	1 1/4	42.7	1 1/4	31	12.70	60	65	12	64	72
BMC87 - 12R	1 1/4	42.7	1 1/2	34	12.70	60	65	12	64	72
BMC88 - 12R	1 1/2	48.6	1 1/2	36	12.70	65	75	12	67	76
BMC88 - 16R	1 1/2	48.6	2	40	15.88	65	75	12	71	76.5

색은 제작용입니다

COPPER TUBE CONNECTOR

Male Elbow

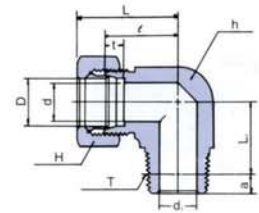

(Brass, Stainless)

품 명	Tube O.D		(PT) h	d	d1	Basic gauge Length a	Width across flat		t	Ø	Approx.	
	D						h	H			L	L1
BLM04 - 01R		4	1/8	2.5	4	3.97	12	12	6	15	22.5	13
BLM06 - 01R		6	1/8	4	4	3.97	14	14	7	20	30.5	14
BLM06 - 02R		6	1/4	4	7	6.01	14	14	7	23	33.5	17
BLM08 - 01R		8	1/8	6	4	3.97	17	17	7	23	33.5	16
BLM08 - 02R		8	1/4	6	7	6.01	17	17	7	23	33.5	18
BLM10 - 02R		10	1/4	8	7	6.01	17	19	7	23	34.5	19
BLM10 - 03R		10	3/8	8	9	6.35	19	19	7	24	35.5	19.5
BLM10 - 04R		10	1/2	8	12	8.16	22	19	7	29	40.5	26
BLM12 - 02R		12	1/4	10	7	6.01	19	22	7	24	35.5	20
BLM12 - 03R		12	3/8	10	9	6.35	19	22	7	24	35.5	20.5
BLM12 - 04R		12	1/2	10	12	8.16	22	22	7	29	40.5	26
BLM15 - 03R		15	3/8	12	9	6.35	24	27	7.5	29	41.5	23.5
BLM15 - 04R		15	1/2	12	12	8.16	24	27	7.5	29	41.5	26
BLM16 - 03R		16	3/8	13	9	6.35	27	30	7.5	32	44.5	25.5
BLM16 - 04R		16	1/2	13	12	8.16	27	30	7.5	32	44.5	27
BLM18 - 03R		18	3/8	14	9	6.35	27	30	8	32	44.5	27.5
BLM18 - 04R		18	1/2	14	12	8.16	27	32	8	32	44.5	30
BLM20 - 04R		20	1/2	17	12	8.16	30	36	8	33	45.5	32
BLM20 - 06R		20	3/4	17	16	9.53	30	36	8	33	45.5	30.5
BLM22 - 04R		22	1/2	18	12	8.16	32	36	9	34	46.5	32
BLM22 - 06R		22	3/4	18	16	9.53	32	36	9	34	46.5	32.5
BLM25 - 06R		25	3/4	20	16	9.53	36	41	10	36	49.5	33.5
BLM25 - 08R		25	1	20	22	10.39	36	41	10	36	49.5	35.5
BLM28 - 06R		28	3/4	22	16	9.53	41	46	10	41	55	37.5
BLM28 - 08R		28	1	22	22	10.39	41	46	10	41	55	39.5
BLM30 - 08R		30	1	25	22	10.39	41	46	10	41	55.5	39.5
BLM30 - 10R		30	1 1/4	25	31	12.70	46	46	10	46	60.5	42.5
BLM32 - 10R		32	1 1/4	26	31	12.70	46	50	11	46	60.5	43.5
BLM35 - 10R		35	1 1/4	28	31	12.70	46	55	11	46	63.5	45.5
BLM38 - 12R		38	1 1/2	32	36	12.70	50	60	12	50	69.5	48.5
BLM40 - 12R		40	1 1/2	32	36	12.70	55	60	12	55	74.5	49.5
BLM42 - 12R		42	1 1/2	34	36	12.70	55	60	12	55	74.5	49.5
BLM50 - 16R		50	2	40	46	15.88	65	75	12	62	83.5	58
BLM81 - 01R	1/8	10.5	1/8	8	4	3.97	17	19	7	23	34.5	17
BLM81 - 02R	1/8	10.5	1/4	8	7	6.01	17	19	7	23	34.5	19
BLM82 - 02R	1/4	13.8	1/4	11	7	6.01	22	24	7.5	28	40	22
BLM82 - 03R	1/4	13.8	3/8	11	9	6.35	22	24	7.5	28	40	22.5
BLM83 - 03R	3/8	17.3	3/8	14	9	6.35	27	32	8	32	44.5	27.5
BLM83 - 04R	3/8	17.3	1/2	14	12	8.16	27	32	8	32	44.5	30
BLM84 - 04R	1/2	21.7	1/2	18	12	8.16	32	36	9	34	46.5	32
BLM84 - 06R	1/2	21.7	3/4	18	16	9.53	32	36	9	34	46.5	32.5
BLM85 - 06R	3/4	27.2	3/4	22	16	9.53	41	46	10	41	55	37.5
BLM85 - 08R	3/4	27.2	1	22	22	10.39	41	46	10	41	55	39.5
BLM86 - 08R	1	34.0	1	28	22	10.39	46	55	11	46	63.5	44.5
BLM86 - 10R	1	34.0	1 1/4	28	31	12.70	46	55	11	46	63.5	45.5
BLM87 - 10R	1 1/4	42.7	1 1/4	34	31	12.70	60	65	12	57	77.5	51.5
BLM87 - 12R	1 1/4	42.7	1 1/2	34	36	12.70	60	75	12	57	77.5	51.5
BLM88 - 12R	1 1/2	48.6	1 1/2	40	36	12.70	65	75	12	62	83.5	57.5
BLM88 - 16R	1 1/2	48.6	2	40	46	15.88	65	75	12	62	83.5	58

색은 제작용입니다

Straight Union

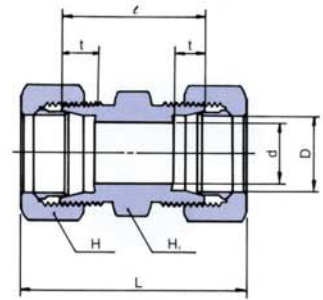

(Steel, Brass, Stainless)

품명	Tube O.D			d	Width across flat		t	ℓ	Approx. L
	D				H1	H			
BU - 04		4		2.5	12	12	6	20	35
BU - 06		6		4	14	14	7	30	51
BU - 08		8		6	17	17	7	31	52
BU - 10		10		8	17	19	7	31	54
BU - 12		12		10	19	22	7	31	54
BU - 15		15		12	24	27	7.5	36	61
BU - 16		16		13	27	30	7.5	36	61
BU - 18		18		14	27	32	8	36	61
BU - 20		20		17	30	36	8	38	63
BU - 22		22		18	32	36	9	38	63
BU - 25		25		20	36	41	10	39	66
BU - 28		28		22	41	46	10	43	71
BU - 30		30		25	41	46	10	43	72
BU - 32		32		26	46	50	11	44	73
BU - 35		35		28	46	55	11	44	79
BU - 38		38		32	50	60	12	46	85
BU - 40		40		32	55	60	12	55	94
BU - 42		42		34	55	60	12	55	94
BU - 50		50		40	65	75	12	60	103
BU - 81	1/8		10.5	8	17	19	7	31	54
BU - 82	1/4		13.8	11	22	24	7.5	36	60
BU - 83	3/8		17.3	14	27	32	8	36	61
BU - 84	1/2		21.7	18	32	36	9	38	63
BU - 85	3/4		27.2	22	41	46	10	43	71
BU - 86	1		34.0	28	46	55	11	44	79
BU - 87	1 1/4		42.7	34	60	65	12	57	98
BU - 88	1 1/2		48.6	40	65	75	12	60	103

색은 제작품입니다

COPPER TUBE CONNECTOR

Union Elbow



(Steel, Brass, Stainless)

품명	Tube O.D		d	Width across flat		t	ℓ	Approx. L	
	D			h	H				
BL - 04		4	2.5	12	12	6	15	22.5	
BL - 06		6	4	14	14	7	20	30.5	
BL - 08		8	6	17	17	7	23	33.5	
BL - 10		10	8	17	19	7	23	34.5	
BL - 12		12	10	19	22	7	24	35.5	
BL - 15		15	12	24	27	7.5	29	41.5	
BL - 16		16	13	27	30	7.5	32	44.5	
BL - 18		18	14	27	32	8	32	44.5	
BL - 20		20	17	30	36	8	33	45.5	
BL - 22		22	18	32	36	9	34	46.5	
BL - 25		25	20	36	41	10	36	49.5	
BL - 28		28	22	41	46	10	41	55	
BL - 30		30	25	41	46	10	41	55.5	
BL - 32		32	26	46	50	11	45	59.5	
BL - 35		35	28	46	55	11	46	63.5	
BL - 38		38	32	50	60	12	50	69.5	
BL - 40		40	32	55	60	12	55	74.5	
BL - 42		42	34	55	60	12	55	74.5	
BL - 50		50	40	65	75	12	62	83.5	
BL - 81	1/8		10.5	8	17	19	7	23	34.5
BL - 82	1/4		13.8	11	22	24	7.5	28	40
BL - 83	3/8		17.3	14	27	32	8	32	44.5
BL - 84	1/2		21.7	18	32	36	9	34	46.5
BL - 85	3/4		27.2	22	41	46	10	41	55
BL - 86	1		34.0	28	46	55	11	46	63.5
BL - 87	1 1/4		42.7	34	60	65	12	57	77.5
BL - 88	1 1/2		48.6	40	65	75	12	62	83.5

색은 제작용입니다

Union Tee

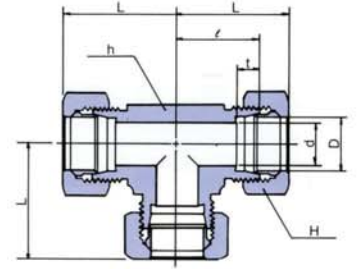

(Steel, Brass, Stainless)

품 명	Tube O.D		d	Width across flat		t	ℓ	Approx. L	
	D			h	H				
BT - 04		4	2.5	12	12	6	15	22.5	
BT - 06		6	4	14	14	7	20	30.5	
BT - 08		8	6	17	17	7	23	33.5	
BT - 10		10	8	17	19	7	23	34.5	
BT - 12		12	10	19	22	7	24	35.5	
BT - 15		15	12	24	27	7.5	29	41.5	
BT - 16		16	13	27	30	7.5	32	44.5	
BT - 18		18	14	27	32	8	32	44.5	
BT - 20		20	17	30	36	8	33	45.5	
BT - 22		22	18	32	36	9	34	46.5	
BT - 25		25	20	36	41	10	36	49.5	
BT - 28		28	22	41	46	10	41	55	
BT - 30		30	25	41	46	10	41	55.5	
BT - 32		32	26	46	50	11	45	59.5	
BT - 35		35	28	46	55	11	46	63.5	
BT - 38		38	32	50	60	12	50	69.5	
BT - 40		40	32	55	60	12	55	74.5	
BT - 42		42	34	55	60	12	55	74.5	
BT - 50		50	40	65	75	12	62	83.5	
BT - 81	1/8		10.5	8	17	19	7	23	34.5
BT - 82	1/4		13.8	11	22	24	7.5	28	40
BT - 83	3/8		17.3	14	27	32	8	32	44.5
BT - 84	1/2		21.7	18	32	36	9	34	46.5
BT - 85	3/4		27.2	22	41	46	10	41	55
BT - 86	1		34.0	28	46	55	11	46	63.5
BT - 87	1 1/4		42.7	34	60	65	12	57	77.5
BT - 88	1 1/2		48.6	40	65	75	12	62	83.5

■ 색은 제작용입니다

COPPER TUBE CONNECTOR

Straight Bulkhead Union

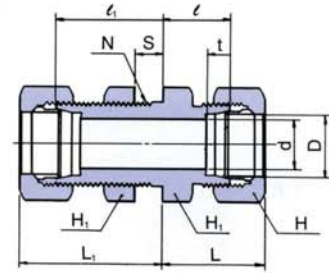

(Steel, Brass, Stainless)

품 명	Tube O.D		d	Width across flat		t	Q 1	Q	Approx.		Panel Hole D till size N	Max. Panel thickness S
	D			H1	H				L1	L		
BBU - 04		4	2.5	14	12	6	25	14	32.5	21.5	10.5	13
BBU - 06		6	4	17	14	7	32	19	42.5	29.5	12.5	13
BBU - 08		8	6	19	17	7	32	19	42.5	29.5	14.5	13
BBU - 10		10	8	22	19	7	32	20	43.5	31.5	16.5	13
BBU - 12		12	10	24	22	7	32	20	43.5	31.5	18.5	13
BBU - 15		15	12	27	27	7.5	37	22	49.5	34.5	22.5	15
BBU - 16		16	13	30	30	7.5	37	24	49.5	36.5	24.5	15
BBU - 18		18	14	32	32	8	39	24	51.5	36.5	26.5	15
BBU - 20		20	17	32	36	8	39	24	51.5	36.5	28.5	15
BBU - 22		22	18	36	36	9	39	25	51.5	37.5	30.5	15
BBU - 25		25	20	41	41	10	39	25	52.5	38.5	35.5	15
BBU - 28		28	22	46	46	10	41	28	55	42	38.5	15
BBU - 30		30	25	46	46	10	41	28	55.5	42.5	40.5	15
BBU - 32		32	26	50	50	11	43	30	57.5	44.5	42.5	15
BBU - 35		35	28	50	55	11	43	30	60.5	47.5	45.5	15
BBU - 38		38	32	55	60	12	45	31	64.5	50.5	48.5	15
BBU - 40		40	32	60	60	12	50	37	69.5	56.5	52.5	15
BBU - 50		50	40	70	75	12	50	43	71.5	64.5	64.5	15
BBU - 81	1/8		10.5	8	22	19	7	32	43.5	31.5	16.5	15
BBU - 82	1/4		13.8	11	27	24	7.5	37	49	34	20.5	15
BBU - 83	3/8		17.3	14	32	32	8	39	51.5	36.5	26.5	15
BBU - 84	1/2		21.7	18	36	36	9	39	51.5	37.5	30.5	15
BBU - 85	3/4		27.2	22	46	46	10	41	55	42	38.5	15
BBU - 86	1		34.0	28	50	55	11	43	60.5	47.5	45.5	15
BBU - 87	1 1/4		42.7	34	65	65	12	50	70.5	60.5	56.5	15
BBU - 88	1 1/2		48.6	40	70	75	12	50	71.5	64.5	64.5	15

■ 색은 제작품입니다

Male Connector(For Copper Gasket)

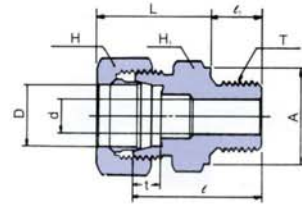

(Steel, Stainless)

품 명	Tube O.D		(PT) T	d	Width across flat		t	A	Q 1	Q	Approx. L
	D				H1	H					
BMC04 - 01G		4	1/8	2.5	14	12	6	14	8	23	22.5
BMC06 - 01G		6	1/8	4	14	14	7	14	8	28	30.5
BMC06 - 02G		6	1/4	4	19	14	7	18	12	33	31.5
BMC08 - 01G		8	1/8	4	17	17	7	14	8	28	30.5
BMC08 - 02G		8	1/4	6	19	17	7	18	12	33	31.5
BMC10 - 02G		10	1/4	6	19	19	7	18	12	33	32.5
BMC10 - 03G		10	3/8	8	22	19	7	21.5	12	34	33.5
BMC12 - 02G		12	1/4	6	19	22	7	18	12	33	32.5
BMC12 - 03G		12	3/8	8	22	22	7	21.5	12	34	33.5
BMC12 - 04G		12	1/2	10	27	22	7	25.5	14	39	36.5
BMC15 - 03G		15	3/8	8	24	27	7.5	21.5	12	37	37.5
BMC15 - 04G		15	1/2	12	27	27	7.5	25.5	14	41	39.5
BMC16 - 04G		16	1/2	12	27	30	7.5	25.5	14	41	39.5
BMC18 - 04G		18	1/2	12	27	32	8	25.5	14	41	39.5
BMC20 - 06G		20	3/4	16	32	36	8	31.5	16	46	42.5
BMC22 - 04G		22	1/2	12	32	36	9	25.5	14	43	41.5
BMC22 - 06G		22	3/4	16	32	36	9	31.5	16	46	42.5
BMC25 - 06G		25	3/4	16	36	41	10	31.5	16	46	43.5
BMC25 - 08G		25	1	20	41	41	10	38	18	50	45.5
BMC28 - 08G		28	1	22	41	46	10	38	18	52	48
BMC30 - 08G		30	1	22	41	46	10	38	18	52	48.5
BMC30 - 10G		30	1 1/4	25	50	46	10	48.5	20	57	51.5
BMC32 - 10G		32	1 1/4	26	50	50	11	48.5	20	57	51.5
BMC35 - 10G		35	1 1/4	28	50	55	11	48.5	20	57	54.5
BMC38 - 12G		38	1 1/2	32	55	60	12	53.5	21	58	56.5
BMC40 - 12G		40	1 1/2	32	55	60	12	53.5	21	62	60.5
BMC42 - 12G		42	1 1/2	34	55	60	12	53.5	21	62	60.5
BMC50 - 16G		50	2	40	70	75	12	66	25	73	69.5
BMC81 - 01G	1/8		1/8	4	17	19	7	14	8	29	32.5
BMC81 - 02G	1/8		1/4	6	19	19	7	18	12	33	32.5
BMC82 - 02G	1/4		1/4	6	22	24	7.5	18	12	36	36
BMC82 - 03G	1/4		3/8	8	22	24	7.5	21.5	12	36	36
BMC83 - 03G	3/8		3/8	8	27	32	8	21.5	12	38	38.5
BMC83 - 04G	3/8		1/2	12	27	32	8	25.5	14	41	39.5
BMC84 - 04G	1/2		1/2	12	32	36	9	25.5	14	43	41.5
BMC84 - 06G	1/2		3/4	16	32	36	9	31.5	16	46	42.5
BMC85 - 06G	3/4		3/4	16	41	46	10	31.5	16	50	48
BMC85 - 08G	3/4		1	22	41	46	10	38	18	52	48
BMC86 - 08G	1		1	22	46	55	11	38	18	54	53.5
BMC86 - 10G	1		1 1/4	28	50	55	11	48.5	20	57	54.5
BMC87 - 10G	1 1/4		1 1/4	31	60	65	12	48.5	20	63	63.5
BMC87 - 12G	1 1/4		1 1/2	34	60	65	12	53.5	21	64	63.5
BMC88 - 12G	1 1/2		1 1/2	36	65	75	12	53.5	21	65	65.5
BMC88 - 16G	1 1/2		2	40	70	75	12	66	25	73	69.5

색은 제작품입니다

Male Branch Tee

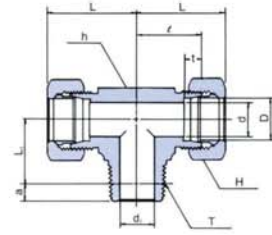

(Steel, Stainless)

품 명	Tube O.D		(PT) T	d	d1	Basic gauge Length a	Width across flat		t	ℓ	Approx.		
	D						h	H			L	L1	
BBTM04 - 01R		4	1/8	2.5	4	3.97	12	12	6	15	22.5	13	
BBTM06 - 01R		6	1/8	4	4	3.97	14	14	7	20	30.5	14	
BBTM06 - 02R		6	1/4	4	7	6.01	17	14	7	23	33.5	17	
BBTM08 - 01R		8	1/8	6	4	3.97	17	17	7	23	33.5	16	
BBTM08 - 02R		8	1/4	6	7	6.01	17	17	7	23	33.5	18	
BBTM10 - 02R		10	1/4	8	7	6.01	17	19	7	23	34.5	19	
BBTM10 - 03R		10	3/8	8	9	6.35	19	19	7	24	35.5	19.5	
BBTM12 - 02R		12	1/4	10	7	6.01	19	22	7	24	35.5	18	
BBTM12 - 03R		12	3/8	10	9	6.35	19	22	7	24	35.5	20.5	
BBTM15 - 03R		15	3/8	12	9	6.35	24	27	7.5	29	41.5	23.5	
BBTM15 - 04R		15	1/2	12	12	8.16	24	27	7.5	29	41.5	26	
BBTM16 - 04R		16	1/2	13	12	8.16	27	30	7.5	32	44.5	27	
BBTM18 - 04R		18	1/2	14	12	8.16	27	32	8	32	44.5	30	
BBTM20 - 06R		20	3/4	17	16	9.53	30	36	8	33	45.5	30.5	
BBTM22 - 06R		22	3/4	18	16	9.53	32	36	9	34	46.5	32.5	
BBTM25 - 06R		25	3/4	20	16	9.53	36	41	10	36	49.5	33.5	
BBTM25 - 08R		25	1	20	22	10.39	36	41	10	36	49.5	35.5	
BBTM28 - 08R		28	1	22	22	10.39	41	46	10	41	55	39.5	
BBTM30 - 08R		30	1	25	22	10.39	41	46	10	41	55.5	39.5	
BBTM30 - 10R		30	1 1/4	25	31	12.70	46	46	10	46	60.5	42.5	
BBTM32 - 10R		32	1 1/4	26	31	12.70	46	50	11	46	60.5	43.5	
BBTM35 - 10R		35	1 1/4	28	31	12.70	46	55	11	46	63.5	45.5	
BBTM38 - 12R		38	1 1/2	32	36	12.70	50	60	12	50	69.5	48.5	
BBTM40 - 12R		40	1 1/2	32	36	12.70	55	60	12	55	74.5	49.5	
BBTM50 - 16R		50	2	40	46	15.88	65	75	12	62	83.5	58	
BBTM81 - 02R	1/8		10.5	1/4	8	7	6.01	17	19	7	23	34.5	19
BBTM82 - 03R	1/4		13.8	3/8	11	9	6.35	22	24	7.5	28	40	22.5
BBTM83 - 04R	3/8		17.3	1/2	14	12	8.16	27	32	8	32	44.5	30
BBTM84 - 06R	1/2		21.7	3/4	18	16	9.53	32	36	9	34	46.5	32.5
BBTM85 - 08R	3/4		27.2	1	22	22	10.39	41	46	10	41	55	39.5
BBTM86 - 10R	1		34.0	1 1/4	28	31	12.70	46	55	11	46	63.5	45.5
BBTM87 - 12R	1 1/4		42.7	1 1/2	34	36	12.70	60	65	12	57	77.5	51.5
BBTM88 - 16R	1 1/2		48.6	2	40	46	15.88	65	75	12	62	83.5	58

■ 색은 제작용입니다

Male Run Tee

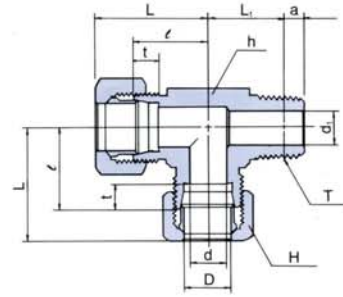

(Steel, Stainless)

품 명	Tube O.D		(PT) T	d	d1	Basic gauge Length a	Width across flat		t	ℓ	Approx.		
	D						h	H			L	L1	
BRTM04 - 01R		4	1/8	2.5	4	3.97	12	12	6	15	22.5	13	
BRTM06 - 01R		6	1/8	4	4	3.97	14	14	7	20	30.5	14	
BRTM06 - 02R		6	1/4	4	7	6.01	17	14	7	23	33.5	17	
BRTM08 - 01R		8	1/8	6	4	3.97	17	17	7	23	33.5	16	
BRTM08 - 02R		8	1/4	6	7	6.01	17	17	7	23	33.5	18	
BRTM10 - 02R		10	1/4	8	7	6.01	17	19	7	23	34.5	19	
BRTM10 - 03R		10	3/8	8	9	6.35	19	19	7	24	35.5	19.5	
BRTM12 - 02R		12	1/4	10	7	6.01	19	22	7	24	35.5	18	
BRTM12 - 03R		12	3/8	10	9	6.35	19	22	7	24	35.5	20.5	
BRTM15 - 03R		15	3/8	12	9	6.35	24	27	7.5	29	41.5	23.5	
BRTM15 - 04R		15	1/2	12	12	8.16	24	27	7.5	29	41.5	26	
BRTM16 - 04R		16	1/2	13	12	8.16	27	30	7.5	32	44.5	27	
BRTM18 - 04R		18	1/2	14	12	8.16	27	32	8	32	44.5	30	
BRTM20 - 06R		20	3/4	17	16	9.53	30	36	8	33	45.5	30.5	
BRTM22 - 06R		22	3/4	18	16	9.53	32	36	9	34	46.5	32.5	
BRTM25 - 06R		25	3/4	20	16	9.53	36	41	10	36	49.5	33.5	
BRTM25 - 08R		25	1	20	22	10.39	36	41	10	36	49.5	35.5	
BRTM28 - 08R		28	1	22	22	10.39	41	46	10	41	55	39.5	
BRTM30 - 08R		30	1	25	22	10.39	41	46	10	41	55.5	39.5	
BRTM30 - 10R		30	1 1/4	25	31	12.70	46	46	10	46	60.5	42.5	
BRTM32 - 10R		32	1 1/4	26	31	12.70	46	50	11	46	60.5	43.5	
BRTM35 - 10R		35	1 1/4	28	31	12.70	46	55	11	46	63.5	45.5	
BRTM38 - 12R		38	1 1/2	32	36	12.70	50	60	12	50	69.5	48.5	
BRTM40 - 12R		40	1 1/2	32	36	12.70	55	60	12	55	74.5	49.5	
BRTM50 - 16R		50	2	40	46	15.88	65	75	12	62	83.5	58	
BRTM81 - 02R	1/8		10.5	1/4	8	7	6.01	17	19	7	23	34.5	19
BRTM82 - 03R	1/4		13.8	3/8	11	9	6.35	22	24	7.5	28	40	22.5
BRTM83 - 04R	3/8		17.3	1/2	14	12	8.16	27	32	8	32	44.5	30
BRTM84 - 06R	1/2		21.7	3/4	18	16	9.53	32	36	9	34	46.5	32.5
BRTM85 - 08R	3/4		27.2	1	22	22	10.39	41	46	10	41	55	39.5
BRTM86 - 10R	1		34.0	1 1/4	28	31	12.70	46	55	11	46	63.5	45.5
BRTM87 - 12R	1 1/4		42.7	1 1/2	34	36	12.70	60	65	12	57	77.5	51.5
BRTM88 - 16R	1 1/2		48.6	2	40	46	15.88	65	75	12	62	83.5	58

색은 제작용입니다

Female Connector

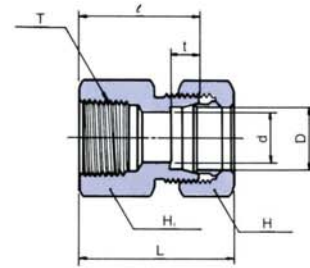

(Steel, Brass, Stainless)

품 명	Tube O.D		(PT) T	d	Width across flat		t	ℓ	Approx. L	
	D				H1	H				
BFC06 - 01R		6	1/8	4	17	14	7	25	35.5	
BFC08 - 02R		8	1/4	6	19	17	7	30	40.5	
BFC10 - 02R		10	1/4	8	19	19	7	30	41.5	
BFC10 - 03R		10	3/8	8	24	19	7	32	43.5	
BFC12 - 02R		12	1/4	10	19	22	7	30	41.5	
BFC12 - 03R		12	3/8	10	24	22	7	32	43.5	
BFC15 - 03R		15	3/8	12	24	27	7.5	34	46.5	
BFC15 - 04R		15	1/2	12	30	27	7.5	39	51.5	
BFC16 - 04R		16	1/2	13	30	30	7.5	39	51.5	
BFC18 - 04R		18	1/2	14	30	32	8	39	51.5	
BFC20 - 06R		20	3/4	17	36	36	8	41	53.5	
BFC22 - 06R		22	3/4	18	36	36	9	41	53.5	
BFC25 - 06R		25	3/4	20	36	41	10	41	54.5	
BFC25 - 08R		25	1	20	46	41	10	45	58.5	
BFC28 - 08R		28	1	22	46	46	10	47	61	
BFC30 - 08R		30	1	25	46	46	10	47	61.5	
BFC30 - 10R		30	1 1/4	25	55	46	10	51	65.5	
BFC32 - 10R		32	1 1/4	26	55	50	11	51	65.5	
BFC35 - 10R		35	1 1/4	28	55	55	11	51	68.5	
BFC38 - 12R		38	1 1/2	32	65	60	12	51	70.5	
BFC40 - 12R		40	1 1/2	32	65	60	12	55	74.5	
BFC42 - 12R		42	1 1/2	34	65	60	12	55	74.5	
BFC50 - 16R		50	2	40	80	75	12	60	81.5	
BFC81 - 02R	1/8		10.5	1/4	8	19	19	7	30	41.5
BFC82 - 03R	1/4		13.8	3/8	11	24	24	7.5	34	46
BFC83 - 04R	3/8		17.3	1/2	14	30	32	8	39	51.5
BFC84 - 06R	1/2		21.7	3/4	18	36	36	9	41	53.5
BFC85 - 06R	3/4		27.2	1	22	46	46	10	47	61
BFC86 - 10R	1		34.0	1 1/4	28	55	55	11	51	68.5
BFC87 - 12R	1 1/4		42.7	1 1/2	34	65	65	12	55	78.5
BFC88 - 16R	1 1/2		48.6	2	40	80	75	12	60	81.5

■ 색은 제작용입니다

Gauge Connector

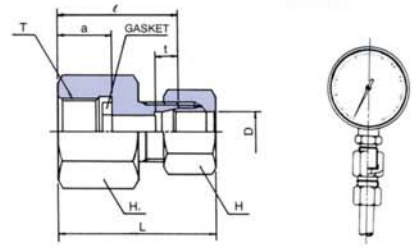

(Steel, Stainless)

품 명	Tube O.D		a	Width across flat		t	φ	Approx. L	Gasket part No
	D	(PT) T		H1	H				
BGC04 - 02G	4	1/4	14	19	12	6	29	36.5	-01
BGC04 - 03G	4	3/8	15	24	12	6	30	37.5	-02
BGC06 - 02G	6	1/4	14	19	14	7	32	42.5	-01
BGC06 - 03G	6	3/8	15	24	14	7	34	44.5	-02
BGC06 - 04G	6	1/2	16	30	14	7	36	46.5	-03
BGC08 - 02G	8	1/4	14	19	17	7	32	42.5	-01
BGC08 - 03G	8	3/8	15	24	17	7	34	44.5	-02
BGC08 - 04G	8	1/2	16	30	17	7	36	46.5	-03
BGC10 - 02G	10	1/4	14	19	19	7	32	43.5	-01
BGC10 - 03G	10	3/8	15	24	19	7	34	45.5	-02
BGC10 - 04G	10	1/2	16	30	19	7	36	47.5	-03
BGC12 - 02G	12	1/4	14	19	22	7	32	43.5	-01
BGC12 - 03G	12	3/8	15	24	22	7	34	45.5	-02
BGC12 - 04G	12	1/2	16	30	22	7	36	47.5	-03

Nut

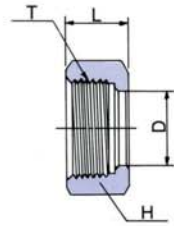

Sleeve

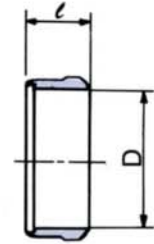

(Steel, Brass, Stainless)

품 명	Tube O.D		T	Width across flat	
		D		H	L
MBN - 04		4	M10 x 1.25	12	10.5
MBN - 06		6	M12 x 1.5	14	15
MBN - 08		8	M14 x 1.5	17	15
MBN - 10		10	M16 x 1.5	19	16
MBN - 12		12	M18 x 1.5	22	16
MBN - 15		15	M22 x 1.5	27	19
MBN - 16		16	M24 x 1.5	30	19
MBN - 18		18	M26 x 1.5	32	19
MBN - 20		20	M28 x 1.5	36	19
MBN - 22		22	M30 x 1.5	36	19
MBN - 25		25	M35 x 1.5	41	20
MBN - 28		28	M38 x 1.5	46	21
MBN - 30		30	M40 x 1.5	46	22
MBN - 32		32	M42 x 1.5	50	22
MBN - 35		35	M45 x 1.5	55	25
MBN - 38		38	M48 x 1.5	60	27
MBN - 40		40	M52 x 2	60	29.5
MBN - 42		42	M52 x 2	60	29.5
MBN - 50		50	M64 x 2	75	31.5
MBN - 81	1/8	10.5	M16 x 1.5	19	16
MBN - 82	1/4	13.8	M20 x 1.5	24	18
MBN - 83	3/8	17.3	M26 x 1.5	32	19
MBN - 84	1/2	21.7	M30 x 1.5	36	19
MBN - 85	3/4	27.2	M38 x 1.5	46	21
MBN - 86	1	34.0	M45 x 1.5	55	25
MBN - 87	1 1/4	42.7	M56 x 2	65	30.5
MBN - 88	1 1/2	48.6	M64 x 2	75	31.5

■ 색은 제작품입니다

품 명	Tube O.D			ℓ
		D		
MBS - 04		4		10.5
MBS - 06		6		15
MBS - 08		8		15
MBS - 10		10		16
MBS - 12		12		16
MBS - 15		15		19
MBS - 16		16		19
MBS - 18		18		19
MBS - 20		20		19
MBS - 22		22		19
MBS - 25		25		20
MBS - 28		28		21
MBS - 30		30		22
MBS - 32		32		22
MBS - 35		35		25
MBS - 38		38		27
MBS - 40		40		29.5
MBS - 42		42		29.5
MBS - 50		50		31.5
MBS - 81	1/8		10.5	16
MBS - 82	1/4		13.8	18
MBS - 83	3/8		17.3	19
MBS - 84	1/2		21.7	19
MBS - 85	3/4		27.2	21
MBS - 86	1		34.0	25
MBS - 87	1 1/4		42.7	30.5
MBS - 88	1 1/2		48.6	31.5

■ 색은 제작품입니다

YM NIPPLE

Hyd's Hose Adaptor

Stainless Steel, Steel

고압 HOSE용 연결 아답터
 고압 HOSE용 ELBOW
 고압 HOSE용 45° ELBOW
 고압 HOSE용 UNION
 010 호스용 아답터
 090 90° 호스용 아답터
 045 45° 호스용 아답터
 110 호스용 아답터
 190 90° 호스용 아답터
 145 45° 호스용 아답터
 050/150 호스용 아답터
 STEEL FITTING



고압 Hose용 연결 Adaptor

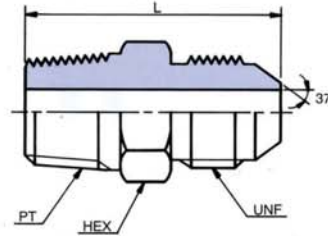

(Steel, Stainless)

품 명	PT	UNF	Hex	L
MFM 3/16-1/8	1/8	7/16 x 20	12	29
MFM 3/16-1/4	1/4	7/16 x 20	14	32
MFM 1/4-1/8	1/8	1/2 x 20	14	31
MFM 1/4-1/4	1/4	1/2 x 20	14	34
MFM 1/4-3/8	3/8	1/2 x 20	14	36
MFM 5/16-1/4	1/4	9/16 x 18	14	34
MFM 5/16-3/8	3/8	9/16 x 18	17	37
MFM 3/8-1/4	1/4	3/4 x 16	19	39
MFM 3/8-3/8	3/8	3/4 x 16	19	40
MFM 3/8-1/2	1/2	3/4 x 16	22	44
MFM 1/2-3/8	3/8	7/8 x 14	22	46
MFM 1/2-1/2	1/2	7/8 x 14	22	46
MFM 1/2-3/4	3/4	7/8 x 14	27	47
MFM 3/4-1/2	1/2	1 1/16 x 12	27	50
MFM 3/4-3/4	3/4	1 1/16 x 12	27	52
MFM 3/4-1	1	1 1/16 x 12	35	58
MFM 1-3/4	3/4	1 5/16 x 12	35	55
MFM 1-1	1	1 5/16 x 12	35	59
MFM 1-1 1/4	1 1/4	1 5/16 x 12	41	65
MFM 1 1/4-1	1	1 5/8 x 12	41	65
MFM 1 1/4-1 1/4	1 1/4	1 5/8 x 12	41	68
MFM 1 1/4-1 1/2	1 1/2	1 5/8 x 12	50	71
MFM 1 1/2-1 1/4	1 1/4	1 3/4 x 12	50	70
MFM 1 1/2-1 1/2	1 1/2	1 3/4 x 12	50	70
MFM 2-2	2	2 1/2 x 12	60	85

■ 색은 제작품입니다

고압 Hose용 Elbow

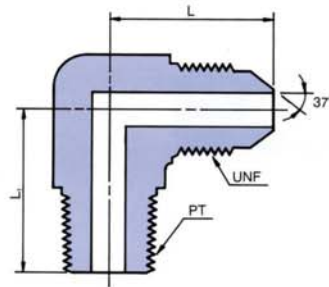

(Steel, Stainless)

품 명	PT	UNF	L1	L
MFL 3/16-1/8	1/8	7/16 x 20	21	22
MFL 3/16-1/4	1/4	7/16 x 20	24	23
MFL 1/4-1/8	1/8	1/2 x 20	24	28
MFL 1/4-1/4	1/4	1/2 x 20	25	24
MFL 1/4-3/8	3/8	1/2 x 20	30	30
MFL 5/16-1/4	1/4	9/16 x 18	25	25
MFL 5/16-3/8	3/8	9/16 x 18	30	30
MFL 3/8-1/4	1/4	3/4 x 16	31	33
MFL 3/8-3/8	3/8	3/4 x 16	32	31
MFL 3/8-1/2	1/2	3/4 x 16	37	35
MFL 1/2-3/8	3/8	7/8 x 14	35	37
MFL 1/2-1/2	1/2	7/8 x 14	34	34
MFL 1/2-3/4	3/4	7/8 x 14	40	40
MFL 3/4-1/2	1/2	1 1/16 x 12	40	40
MFL 3/4-3/4	3/4	1 1/16 x 12	40	40
MFL 3/4-1	1	1 1/16 x 12	50	50
MFL 1-3/4	3/4	1 5/16 x 12	52	52
MFL 1-1	1	1 5/16 x 12	50	50
MFL 1-1 1/4	1 1/4	1 5/16 x 12	56	56
MFL 1 1/4-1	1	1 5/8 x 12	56	56
MFL 1 1/4-1 1/4	1 1/4	1 5/8 x 12	56	56
MFL 1 1/4-1 1/2	1 1/2	1 5/8 x 12	60	60
MFL 1 1/2-1 1/4	1 1/4	1 3/4 x 12	60	60
MFL 1 1/2-1 1/2	1 1/2	1 3/4 x 12	60	60
MFL 2-2	2	2 1/2 x 12	75	75

■ 색은 제작품입니다

고압 Hose용 45° Elbow

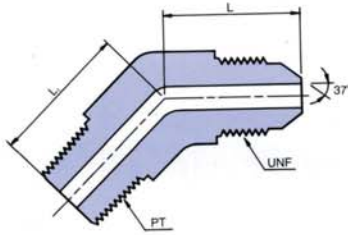

(Stainless Steel, Steel)

품 명	PT	UNF	L1	L
MFLL 3/16-1/8	1/8	7/16 x 20	20	20
MFLL 3/16-1/4	1/4	7/16 x 20	20	20
MFLL 1/4-1/4	1/4	1/2 x 20	21	20
MFLL 5/16-1/4	1/4	9/16 x 18	21	20
MFLL 3/8-3/8	3/8	3/4 x 16	22	24
MFLL 1/2-1/2	1/2	7/8 x 14	26	27
MFLL 3/4-3/4	3/4	1 1/16 x 12	30	30
MFLL 1-1	1	1 5/16 x 12	39	37
MFLL 1 1/4-1 1/4	1 1/4	1 5/8 x 12	47	44
MFLL 1 1/2-1 1/2	1 1/2	1 3/4 x 12	44	45
MFLL 2-2	2	2 1/2 x 12	75	75

■ 색은 제품입니다

고압 Hose용 Union

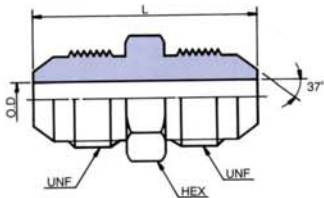

(Stainless Steel, Steel)

품 명	UNF	Hex	L
MFU 1/4	1/2 x 20	14	35
MFU 5/16	9/16 x 18	14	35
MFU 3/8	3/4 x 16	19	43
MFU 1/2	7/8 x 14	22	47
MFU 3/4	1 1/16 x 12	27	56
MFU 1	1 5/16 x 12	35	63
MFU 1 1/4	1 5/8 x 12	41	69
MFU 1 1/2	1 3/4 x 12	50	72
MFU 2	2 1/2 x 12	60	92

■ 색은 제품입니다

010 호스용 아답터 (SE용)

(Stainless Steel, Steel)

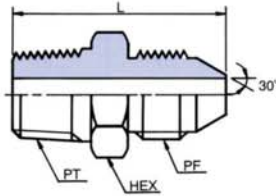

품 명	PT	PF	Hex	L
010-4-4	1/4	1/4	14	33
010-6-6	3/8	3/8	19	39
010-8-8	1/2	1/2	22	48
010-12-12	3/4	3/4	27	51
010-16-16	1	1	35	58
010-20-20	1 1/4	1 1/4	41	68
010-24-24	1 1/2	1 1/2	50	70
010-32-32	2	2	60	85

090 90° 호스용 아답터 (SE용)

(Stainless Steel, Steel)

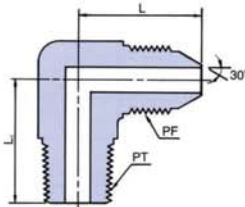

품 명	PT	PF	Hex	L
090-4-4	1/4	1/4	27	26
090-6-6	3/8	3/8	31	31
090-8-8	1/2	1/2	35	35
090-12-12	3/4	3/4	44	40
090-16-16	1	1	48	49
090-20-20	1 1/4	1 1/4	55	55
090-24-24	1 1/2	1 1/2	67	60
090-32-32	2	2	75	75

045 45° 호스용 아답터 (SE용)

(Stainless Steel, Steel)

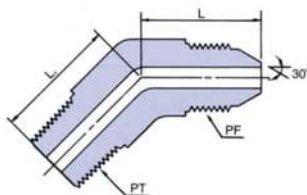

품 명	PT	PF	Hex	L
045-4-4	1/4	1/4	21	20
045-6-6	3/8	3/8	22	24
045-8-8	1/2	1/2	26	27
045-12-12	3/4	3/4	30	30
045-16-16	1	1	39	37
045-20-20	1 1/4	1 1/4	47	44
045-24-24	1 1/2	1 1/2	44	45

110 호스용 아답터 (SF용)

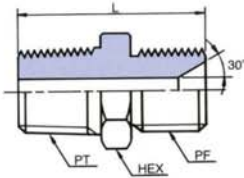

(Stainless Steel, Steel)

품 명	PT	PF	Hex	L
110-4-4	1/4	1/4	14	31
110-6-6	3/8	3/8	19	37
110-8-8	1/2	1/2	22	46
110-12-12	3/4	3/4	27	49
110-16-16	1	1	35	56
110-20-20	1 1/4	1 1/4	41	66
110-24-24	1 1/2	1 1/2	50	68
110-32-32	2	2	60	83

190 90° 호스용 아답터 (SF용)

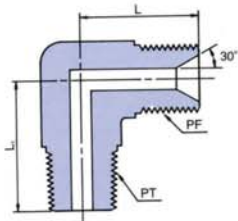

(Stainless Steel, Steel)

품 명	PT	PF	L1	L
190-4-4	1/4	1/4	27	24
190-6-6	3/8	3/8	31	29
190-8-8	1/2	1/2	35	33
190-12-12	3/4	3/4	44	38
190-16-16	1	1	48	47
190-20-20	1 1/4	1 1/4	55	53
190-24-24	1 1/2	1 1/2	67	58
190-32-32	2	2	75	73

145 45° 호스용 아답터 (SF용)

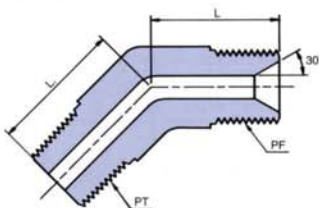

(Stainless Steel, Steel)

품 명	PT	PF	L1	L
145-4-4	1/4	1/4	21	18
145-6-6	3/8	3/8	22	22
145-8-8	1/2	1/2	26	25
145-12-12	3/4	3/4	30	28
145-16-16	1	1	39	35
145-20-20	1 1/4	1 1/4	47	42
145-24-24	1 1/2	1 1/2	44	43

050/150 호스용 아답터 (SE용)

(Stainless Steel, Steel)

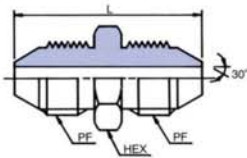

품 명	PF	Hex	L
050-4-4	1/4	14	31
050-6-6	3/8	19	37
050-8-8	1/2	22	46
050-12-12	3/4	27	49
050-16-16	1	35	56
050-20-20	1 1/4	41	66
050-24-24	1 1/2	50	68
050-32-32	2	60	83

■ 색은 제품입니다

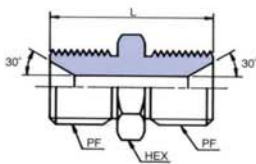

(Stainless Steel, Steel)

품 명	PF	Hex	L
150-4-4	1/4	14	29
150-6-6	3/8	19	35
150-8-8	1/2	22	44
150-12-12	3/4	27	47
150-16-16	1	35	54
150-20-20	1 1/4	41	64
150-24-24	1 1/2	50	66
150-32-32	2	60	81

MCS-1

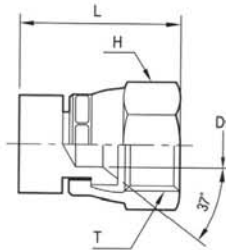

Part No.	T(UNF)	D	H	L
MCS-1-07U	7/16	4.5	16	24
MCS-1-08U	1/2	5.5	16	25
MCS-1-09U	9/16	7.0	10	37
MCS-1-12U	3/4	10	22	31
MCS-1-14U	7/8	12	27	32
MCS-1-17U	1 1/16	15.5	32	34
MCS-1-19U	1 3/16	18	35	34
MCS-1-21U	1 5/16	21	38	39
MCS-1-26U	1 5/8	27.5	50	40
MCS-1-30U	1 7/8	33	55	44

MCS-2

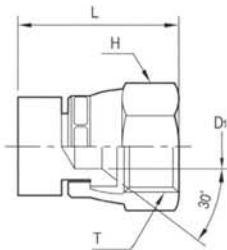

Part No.	T(UNF)	D	H	L
MCS-2-04G	1/4	5.5	19	23.5
MCS-2-06G	3/8	8	22	27
MCS-2-08G	1/2	11.5	27	30
MCS-2-12G	3/4	15.5	32	36
MCS-2-16G	1	20	41	40.5
MCS-2-20G	1 1/4	27	50	43
MCS-2-24G	1 1/2	35	55	46.5

MPA-1

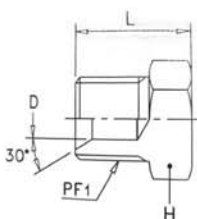

Part No.	T (PF)	D	H		L	
			h-a	h-b	h-a	h-b
MPA-02G	1/8	4.5	12	14	16	14
MPA-04G	1/4	5	14	19	19	18
MPA-06G	3/8	8	19	22	22	20
MPA-08G	1/2	11.5	22	27	28	22
MPA-12G	3/4	16	27	32	30	28
MPA-16G	1	21	35	41	34	33
MPA-20G	1 1/4	27	43	50	38	35
MPA-24G	1 1/2	33	50	55	43	38
MPA-32G	2	43	63.5	70	52	46

MPA-2

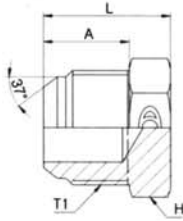

T(UNF)	A	L	H	W.G(g)
MPA 7/16	14	20	14	16.9
MPA 1/2	15	21	14	17.8
MPA 9/16	16	23	16	29.8
MPA 3/4	17	25	22	58.1
MPA 7/8	20	29	24	88.1
MPA 1 1/16	22	33	30	125.3
MPA 1 5/16	25	37	35	193.6
MPA 1 5/8	27	40	43	328.9
MPA 1 3/4	30	43	50	610.8
MPA 2 1/2	35	52	65	937.3

MSWC

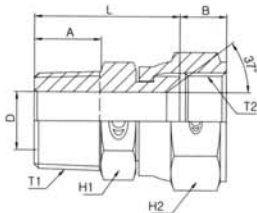

T1(BSPT)	T2(UNF)	A	B	D	H1	H2	L	W.G(g)
PT1/4	MSWC 1/2	14	8.8	5.5	14	16	28.2	36.8
PT3/8	MSWC 3/4	16	11.0	9.0	19	22	36.5	73.9
PT1/2	MSWC 7/8	18	11.0	11.5	22	27	38.5	114.7
PT3/4	MSWC 1 1/16	20	14.5	16.0	27	32	43.0	171.7
PT1	MSWC 1 5/16	23	16.0	20.0	35	41	50.0	346.8

MSWE

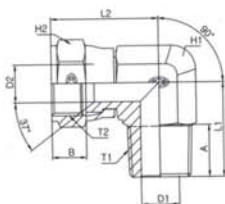

T1(BSPT)	T2(UNF)	A	B	D1	D2	H1	H2	L1	L2	W.G(g)
PT1/4	MSWE 1/2	15	8.8	5.5	5.5	14	16	26	27.0	54.6
PT1/4	MSWE 9/16	15	10.0	5.5	7.0	14	19	26	29.5	63.1
PT3/8	MSWE 3/4	17	11.0	9.0	9.0	19	22	30	35.5	106.9
PT1/2	MSWE 7/8	16	11.0	11.5	11.5	22	27	36	38.5	175.5
PT3/4	MSWE 1 1/16	22	14.5	16.0	16.0	27	32	40	45.5	88.7
PT1	MSWE 1 5/16	25	16.0	20.0	20.0	35	41	48	54.0	569.6

YM NIPPLE

Hyd's Pipe 배관용 Nipple

Stainless Steel, Steel

- 90° Elbow
- Tee
- 45° Elbow
- Full Coupling
- Half Coupling
- Reducing Coupling
- Union
- 90° Elbow
- 45° Elbow
- Street Elbow
- Tee
- Full Coupling
- Half Coupling
- Hex Nipple
- Reducing Nipple
- Hex Socket
- Reducing Socket
- Lench Plug
- Square Head Plug
- Male/Female Adapter Type A
- Hex Bushing
- Male/Female Adapter Type C



90° Elbow

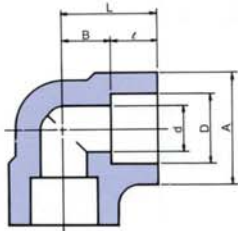

(Stainless Steel, Steel)

품명	Nom. Size	D	∅ Min.	d	A	B	L Min.
----	-----------	---	--------	---	---	---	--------

Sch. 80

MLW02-S80	1/4	14.3	10	9.4	23	11.1	21.1
MLW03-S80	3/8	17.8	10	12.7	27	13.5	23.5
MLW04-S80	1/2	22.2	10	16.1	33	15.9	25.9
MLW06-S80	3/4	27.7	13	21.4	39	19.1	32.1
MLW08-S80	1	34.5	13	27.2	47	22.2	35.2
MLW10-S80	1 1/4	43.2	13	35.5	57	27.0	40.0
MLW12-S80	1 1/2	49.1	13	41.2	63	31.8	44.8
MLW16-S80	2	61.1	16	52.7	76	38.1	54.1

Sch. 160

MLW04-S160	1/2	22.2	13	12.3	39	19.1	32.1
MLW06-S160	3/4	27.7	13	16.2	47	22.2	35.2
MLW08-S160	1	34.5	13	21.2	57	27.0	40.0
MLW10-S160	1 1/4	43.2	13	29.9	63	31.8	44.8
MLW12-S160	1 1/2	49.1	16	34.4	76	38.1	54.1
MLW16-S160	2	61.1	23	43.1	96	41.3	64.3

Tee

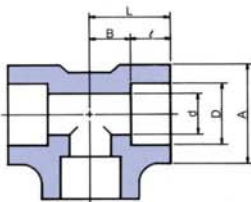

(Stainless Steel, Steel)

품명	Nom. Size	D	∅ Min.	d	A	B	L Min.
----	-----------	---	--------	---	---	---	--------

Sch. 80

MTW02-S80	1/4	14.3	10	9.4	23	11.1	21.1
MTW03-S80	3/8	17.8	10	12.7	27	13.5	23.5
MTW04-S80	1/2	22.2	10	16.1	33	15.9	25.9
MTW06-S80	3/4	27.7	13	21.4	39	19.1	32.1
MTW08-S80	1	34.5	13	27.2	47	22.2	35.2
MTW10-S80	1 1/4	43.2	13	35.5	57	27.0	40.0
MTW12-S80	1 1/2	49.1	13	41.2	63	31.8	44.8
MTW16-S80	2	61.1	16	52.7	76	38.1	54.1

Sch. 160

MTW04-S160	1/2	22.2	13	12.3	39	19.1	32.1
MTW06-S160	3/4	27.7	13	16.2	47	22.2	35.2
MTW08-S160	1	34.5	13	21.2	57	27.0	40.0
MTW10-S160	1 1/4	43.2	13	29.9	63	31.8	44.8
MTW12-S160	1 1/2	49.1	16	34.4	76	38.1	54.1
MTW16-S160	2	61.1	23	43.1	96	41.3	64.3

45° Elbow

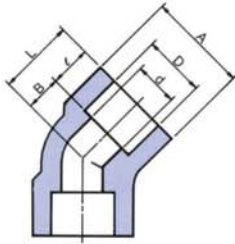

(Stainless Steel, Steel)

품명	Nom. Size	D	ℓ Min.	d	A	B	L Min.
----	-----------	---	--------	---	---	---	--------

Sch. 80

MLLW02-S80	1/4	14.3	10	9.4	23	7.9	17.9
MLLW03-S80	3/8	17.8	10	12.7	27	7.9	17.9
MLLW04-S80	1/2	22.2	10	16.1	33	11.1	21.1
MLLW06-S80	3/4	27.7	13	21.4	39	12.7	25.7
MLLW08-S80	1	34.5	13	27.2	47	14.3	27.3
MLLW10-S80	1 1/4	43.2	13	35.5	57	17.5	30.5
MLLW12-S80	1 1/2	49.1	13	41.2	63	20.6	33.6
MLLW16-S80	2	61.1	16	52.7	76	25.4	41.4

Sch. 160

MLLW04-S160	1/2	22.2	13	12.3	39	12.7	25.7
MLLW06-S160	3/4	27.7	13	16.2	47	14.3	27.3
MLLW08-S160	1	34.5	13	21.2	57	17.5	30.5
MLLW10-S160	1 1/4	43.2	13	29.9	63	20.6	33.6
MLLW12-S160	1 1/2	49.1	16	34.4	76	25.4	41.4
MLLW16-S160	2	61.1	23	43.1	96	28.6	51.6

Union

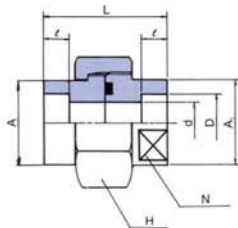

(Stainless Steel, Steel)

품명	Nom. Size	D	ℓ	d	A	A1	N	L	H	L Min.
----	-----------	---	---	---	---	----	---	---	---	--------

MUW-02	1/4	14.3	10	9.4	22	24	21	38	HEX36	P18
MUW-03	3/8	17.8	10	12.7	27	29	26	38	HEX41	P20
MUW-04	1/2	22.2	10	16.1	32	35	32	44	HEX46	G25
MUW-06	3/4	27.7	13	21.4	37	41	37	50	HEX55	G30
MUW-08	1	34.5	13	27.2	44	47	44	56	HEX60	G35
MUW-10	1 1/4	43.2	13	35.5	54	54	51	60	OCT75	G45
MUW-12	1 1/2	49.1	13	41.2	63	65	60	72	OCT85	G50
MUW-16	2	61.1	16	52.7	76	80	75	72	OCT100	G65

Full Coupling

(Stainless Steel, Steel)

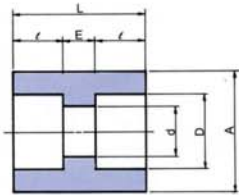

품 명	Nom. Size	D	ℓ	d	A	E	L
-----	-----------	---	---	---	---	---	---

Sch. 80

MWFC02-S80	1/4	14.3	10	9.4	22	6.4	26.4
MWFC03-S80	3/8	17.8	10	12.7	26	6.4	26.4
MWFC04-S80	1/2	22.2	10	16.1	32	9.5	29.5
MWFC06-S80	3/4	27.7	13	21.4	38	9.5	35.5
MWFC08-S80	1	34.5	13	27.2	46	12.7	38.7
MWFC10-S80	1 1/4	43.2	13	35.5	55	12.7	38.7
MWFC12-S80	1 1/2	49.1	13	41.2	63	12.7	38.7
MWFC16-S80	2	61.1	16	52.7	75	19.1	51.1

Sch. 160

MWFC04-S160	1/2	22.2	13	12.3	34	9.5	35.5
MWFC06-S160	3/4	27.7	13	16.2	42	9.5	35.5
MWFC08-S160	1	34.5	13	21.2	52	12.7	38.7
MWFC10-S160	1 1/4	43.2	13	29.9	60	12.7	38.7
MWFC12-S160	1 1/2	49.1	16	34.4	68	12.7	44.7
MWFC16-S160	2	61.1	16	43.1	85	19.1	51.1

Half Coupling

(Stainless Steel, Steel)

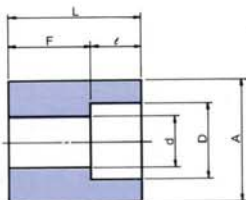

품 명	Nom. Size	D	ℓ	d	A	F	L
-----	-----------	---	---	---	---	---	---

Sch. 80

MWHC02-S80	1/4	14.3	10	9.4	22	15.9	25.9
MWHC03-S80	3/8	17.8	10	12.7	26	17.5	27.5
MWHC04-S80	1/2	22.2	10	16.1	32	22.2	32.2
MWHC06-S80	3/4	27.7	13	21.4	38	23.8	36.8
MWHC08-S80	1	34.5	13	27.2	46	28.6	41.6
MWHC10-S80	1 1/4	43.2	13	35.5	55	30.2	43.2
MWHC12-S80	1 1/2	49.1	13	41.2	63	31.8	44.8
MWHC16-S80	2	61.1	16	52.7	75	41.3	57.3

Sch. 160

MWHC04-S160	1/2	22.2	13	12.3	34	22.2	35.2
MWHC06-S160	3/4	27.7	13	16.2	42	23.8	36.8
MWHC08-S160	1	34.5	13	21.2	52	28.6	41.6
MWHC10-S160	1 1/4	43.2	13	29.9	60	30.2	43.2
MWHC12-S160	1 1/2	49.1	16	34.4	68	31.8	47.8
MWHC16-S160	2	61.1	16	43.1	85	41.3	57.3

Reducing Coupling

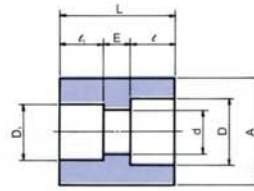

(Stainless Steel, Steel)

품 명	Nom. Size	D	D1	ℓ	ℓ 1	d	A	E	L	
Sch. 80										
MWRC0302-S80	3/8 x 1/4	17.8	14.3	10	10	9.4	26	6.4	26.4	
MWRC0402-S80	1/2 x 1/4	22.2	14.3	10	10	9.4	32	9.5	29.5	
MWRC0403-S80	1/2 x 3/8	22.2	17.8	10	10	12.7	32	9.5	29.5	
MWRC0602-S80	3/4 x 1/4	27.7	14.3	13	10	9.4	38	9.5	32.5	
MWRC0603-S80	3/4 x 3/8	27.7	17.8	13	10	12.7	38	9.5	32.5	
MWRC0604-S80	3/4 x 1/2	27.7	22.2	13	10	16.1	38	9.5	32.5	
MWRC0803-S80	1 x 3/8	34.5	17.8	13	10	12.7	46	12.7	35.7	
MWRC0804-S80	1 x 1/2	34.5	22.2	13	10	16.1	46	12.7	35.7	
MWRC0806-S80	1 x 3/4	34.5	27.7	13	13	21.4	46	12.7	38.7	
MWRC1004-S80	1 1/4 x 1/2	43.2	22.2	13	10	16.1	55	12.7	35.7	
MWRC1006-S80	1 1/4 x 3/4	43.2	27.7	13	13	21.4	55	12.7	38.7	
MWRC1008-S80	1 1/4 x 1	43.2	34.5	13	13	27.2	55	12.7	38.7	
MWRC1206-S80	1 1/2 x 3/4	49.1	27.7	13	13	21.4	63	12.7	38.7	
MWRC1208-S80	1 1/2 x 1	49.1	34.5	13	13	27.2	63	12.7	38.7	
MWRC1210-S80	1 1/2 x 1 1/4	49.1	43.2	13	13	35.5	63	12.7	38.7	
MWRC1608-S80	2 x 1	61.1	34.5	16	13	27.2	75	19.1	48.1	
MWRC1610-S80	2 x 1 1/4	61.1	43.2	16	13	35.5	75	19.1	48.1	
MWRC1612-S80	2 x 1 1/2	61.1	49.1	16	13	41.2	75	19.1	48.1	
Sch. 160										
MWRC0604-S160	3/4 x 1/2	27.7	22.2	13	13	12.3	42	9.5	35.5	
MWRC0804-S160	1 x 1/2	34.5	22.2	13	13	12.3	52	12.7	38.7	
MWRC0806-S160	1 x 3/4	34.5	27.7	13	13	16.2	52	12.7	38.7	
MWRC1004-S160	1 1/4 x 1/2	43.2	22.2	13	13	12.3	60	12.7	38.7	
MWRC1006-S160	1 1/4 x 3/4	43.2	27.7	13	13	16.2	60	12.7	38.7	
MWRC1008-S160	1 1/4 x 1	43.2	34.5	13	13	21.2	60	12.7	38.7	
MWRC1206-S160	1 1/2 x 3/4	49.1	27.7	16	13	16.2	68	12.7	41.7	
MWRC1208-S160	1 1/2 x 1	49.1	34.5	16	13	21.2	68	12.7	41.7	
MWRC1210-S160	1 1/2 x 1 3/4	49.1	43.2	16	13	29.9	68	12.7	41.7	
MWRC1608-S160	2 x 1	61.1	34.5	16	13	21.2	85	19.1	48.1	
MWRC1610-S160	2 x 1 1/4	61.1	43.2	16	13	29.9	85	19.1	48.1	
MWRC1612-S160	2 x 1 1/2	61.1	49.1	16	16	34.4	85	19.1	51.1	

Union



(Stainless Steel, Steel)

품명	Nom. Size	D	ℓ	d	A	A1	N	L	H	L Min.
MUS-02	1/4	14.3	10	9.4	22	24	21	38	HEX36	P18
MUS-03	3/8	17.8	10	12.7	27	29	26	38	HEX41	P20
MUS-04	1/2	22.2	10	16.1	32	35	32	44	HEX46	G25
MUS-06	3/4	27.7	13	21.4	37	41	37	50	HEX55	G30
MUS-08	1	34.5	13	27.2	44	47	44	56	HEX60	G35
MUS-10	1 1/4	43.2	13	35.5	54	54	51	60	OCT75	G45
MUS-12	1 1/2	49.1	13	41.2	63	65	60	72	OCT85	G50
MUS-16	2	61.1	16	52.7	76	80	75	72	OCT100	G65

90° Elbow

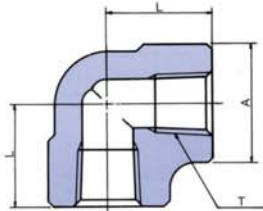

(Stainless Steel, Steel)

품명	T (PT)	A	L
MSL-02R	1/4	23	22.5
MSL-03R	3/8	27	25
MSL-04R	1/2	33	29
MSL-06R	3/4	39	34
MSL-08R	1	47	38
MSL-10R	1 1/4	57	45
MSL-12R	1 1/2	63	51
MSL-16R	2	76	60

45° Elbow

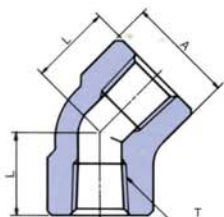

(Stainless Steel, Steel)

품명	T (PT)	A	L
MSLL-02R	1/4	23	20
MSLL-03R	3/8	27	21
MSLL-04R	1/2	33	24
MSLL-06R	3/4	39	27.5
MSLL-08R	1	47	30
MSLL-10R	1 1/4	57	36
MSLL-12R	1 1/2	63	40
MSLL-16R	2	76	47

Street Elbow

(Stainless Steel, Steel)

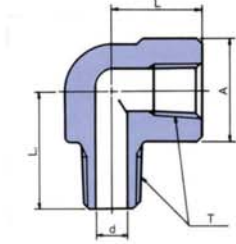

품 명	T (PT)	d	A	L	L1
MSEL-02R	1/4	7	23	14	27
MSEL-03R	3/8	9	27	23	29
MSEL-04R	1/2	12	33	26	36
MSEL-06R	3/4	16	39	31	42
MSEL-08R	1	20	47	33	46
MSEL-10R	1 1/4	28	57	36	54.5
MSEL-12R	1 1/2	32	63	38	59.5
MSEL-16R	2	40	76	46	72

Tee

(Stainless Steel, Steel)

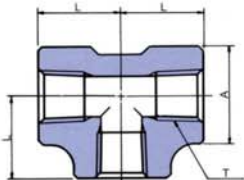

품 명	T (PT)	A	L
MST-02R	1/4	23	22.5
MST-03R	3/8	27	25
MST-04R	1/2	33	29
MST-06R	3/4	39	34
MST-08R	1	47	38
MST-10R	1 1/4	57	45
MST-12R	1 1/2	63	51
MST-16R	2	76	60

Full Coupling

(Stainless Steel, Steel)

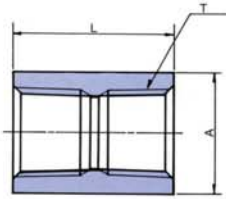

품 명	T (PT)	A	L
MFC-02R	1/4	20	35.1
MFC-03R	3/8	24	38.1
MFC-04R	1/2	30	47.8
MFC-06R	3/4	36	50.8
MFC-08R	1	46	60.5
MFC-10R	1 1/4	60	66.5
MFC-12R	1 1/2	65	79.3
MFC-16R	2	80	85.9

Half Coupling

(Stainless Steel, Steel)

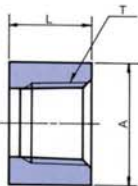

품 명	T (PT)	A	L
MHC-02R	1/4	20	17.6
MHC-03R	3/8	24	19.1
MHC-04R	1/2	30	23.9
MHC-06R	3/4	36	25.4
MHC-08R	1	46	30.3
MHC-10R	1 1/4	60	33.3
MHC-12R	1 1/2	65	39.7
MHC-16R	2	80	43.0

Hex Nipple

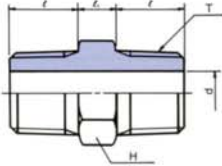

(Stainless Steel, Steel)

품 명	T (PT)	d	H	ℓ	ℓ1
MHN-01R	1/8	4	HEX12	10	6
MHN-02R	1/4	7	HEX17	14	8
MHN-03R	3/8	9	HEX19	15	8
MHN-04R	1/2	12	HEX22	19	9
MHN-06R	3/4	16	HEX27	21	10
MHN-08R	1	20	HEX36	24	11
MHN-10R	1 1/4	28	HEX46	27	12
MHN-12R	1 1/2	32	HEX50	27	14
MHN-16R	2	40	HEX65	31	16

Reducing Nipple

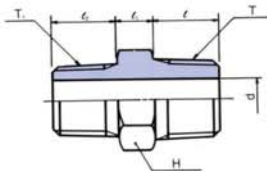

(Stainless Steel, Steel)

품 명	T (PT) × T1 (PT)	d	H	ℓ	ℓ1	ℓ2
MHRN02-01R	1/4 × 1/8	4	HEX17	14	8	10
MHRN03-02R	3/8 × 1/4	7	HEX19	15	8	14
MHRN04-02R	1/2 × 1/4	7	HEX22	19	9	14
MHRN04-03R	1/2 × 3/8	9	HEX22	19	9	15
MHRN06-02R	3/4 × 1/4	7	HEX27	21	10	14
MHRN06-03R	3/4 × 3/8	9	HEX27	21	10	15
MHRN06-04R	3/4 × 1/2	12	HEX27	21	10	19
MHRN08-03R	1 × 3/8	9	HEX36	24	11	15
MHRN08-04R	1 × 1/2	12	HEX36	24	11	19
MHRN08-06R	1 × 3/4	16	HEX36	24	11	21
MHRN10-04R	1 1/4 × 1/2	12	HEX46	27	12	19
MHRN10-06R	1 1/4 × 3/4	16	HEX46	27	12	21
MHRN10-08R	1 1/4 × 1	20	HEX46	27	12	24
MHRN12-06R	1 1/2 × 3/4	16	HEX50	27	14	21
MHRN12-08R	1 1/2 × 1	20	HEX50	27	14	24
MHRN12-10R	1 1/2 × 1 1/4	28	HEX50	27	14	27
MHRN16-08R	2 × 1	20	HEX65	31	16	24
MHRN16-10R	2 × 1 1/4	28	HEX65	31	16	27
MHRN16-12R	2 × 1 1/2	32	HEX65	31	16	27

색은 제작품입니다

Hex Socket

(Stainless Steel, Steel)

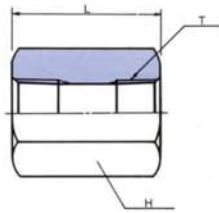

품 명	T (PT)	H	L
MHS-01R	1/8	HEX19	30
MHS-02R	1/4	HEX22	30
MHS-03R	3/8	HEX24	30
MHS-04R	1/2	HEX32	40
MHS-06R	3/4	HEX36	42
MHS-08R	1	HEX46	50
MHS-10R	1 1/4	HEX55	55
MHS-12R	1 1/2	HEX65	55
MHS-16R	2	HEX75	64

Reducing Socket

(Stainless Steel, Steel)

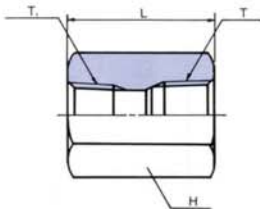

품 명	T (PT)	x	T1 (PT)	H	L
MHRS02-01R	1/4	x	1/8	HEX22	30
MHRS03-02R	3/8	x	1/4	HEX24	30
MHRS04-02R	1/2	x	1/4	HEX32	40
MHRS04-03R	1/2	x	3/8	HEX32	40
MHRS06-02R	3/4	x	1/4	HEX36	42
MHRS06-03R	3/4	x	3/8	HEX36	42
MHRS06-04R	3/4	x	1/2	HEX36	42
MHRS08-03R	1	x	3/8	HEX46	50
MHRS08-04R	1	x	1/2	HEX46	50
MHRS08-06R	1	x	3/4	HEX46	50
MHRS10-04R	1 1/4	x	1/2	HEX55	55
MHRS10-06R	1 1/4	x	3/4	HEX55	55
MHRS10-08R	1 1/4	x	1	HEX55	55
MHRS12-06R	1 1/2	x	3/4	HEX65	55
MHRS12-08R	1 1/2	x	1	HEX65	55
MHRS12-10R	1 1/2	x	1 1/4	HEX65	55
MHRS16-08R	2	x	1	HEX75	64
MHRS16-10R	2	x	1 1/4	HEX75	64
MHRS16-12R	2	x	1 1/2	HEX75	64

색은 제작용입니다

Lench Plug



Steel(SCM4)

품 명	관용나사 (PT)	Hex	L
MLP 1/8	1/8	5	7
MLP 1/4	1/4	6	10
MLP 3/8	3/8	8	12
MLP 1/2	1/2	10	13.5
MLP 3/4	3/4	14	14
MLP 1	1	17	17.5
MLP 1 1/4	1 1/4	22	20
MLP 1 1/2	1 1/2	22	22
MLP 2	2	27	22

Square Head Plug

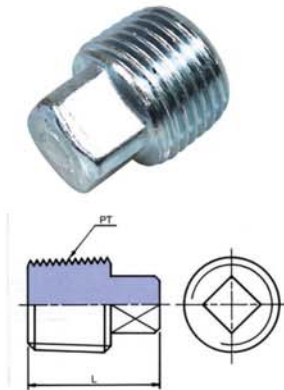

Steel(SUS304)

품 명	관용나사 (PT)	□	L
MSP 1/8	1/8	7	15
MSP 1/4	1/4	9	19
MSP 3/8	3/8	11	20
MSP 1/2	1/2	14	26
MSP 3/4	3/4	18	27
MSP 1	1	22	30

Male/Female Adapter Type A

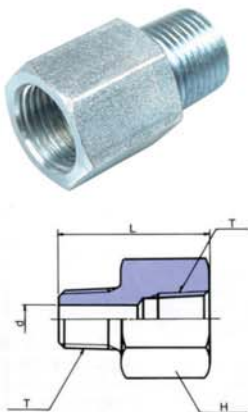

품 명	T (PT)	d	L	H
MHR-02R	1/4	7	33	HEX22
MHR-03R	3/8	9	36	HEX24
MHR-04R	1/2	12	45	HEX32
MHR-06R	3/4	16	50	HEX36
MHR-08R	1	20	58	HEX46
MHR-10R	1 1/4	28	67	HEX55
MHR-12R	1 1/2	32	69	HEX65
MHR-16R	2	40	79	HEX75

색은 제작품입니다

Hex Bushing

(Stainless Steel, Steel)

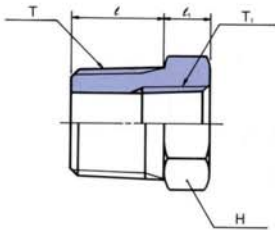

품명	T (PT)	x	T1 (PT)	H	ℓ	ℓ1
MHB02-01R	1/4	x	1/8	HEX17	14	8
MHB03-02R	3/8	x	1/4	HEX19	15	8
MHB04-02R	1/2	x	1/4	HEX24	19	9
MHB04-03R	1/2	x	3/8	HEX24	19	9
MHB06-02R	3/4	x	1/4	HEX30	21	10
MHB06-03R	3/4	x	3/8	HEX30	21	10
MHB06-04R	3/4	x	1/2	HEX30	21	10
MHB08-02R	1	x	1/4	HEX36	24	11
MHB08-03R	1	x	3/8	HEX36	24	11
MHB08-04R	1	x	1/2	HEX36	24	11
MHB08-06R	1	x	3/4	HEX36	24	11
MHB10-04R	1 1/4	x	1/2	HEX46	27	12
MHB10-06R	1 1/4	x	3/4	HEX46	27	12
MHB10-08R	1 1/4	x	1	HEX46	27	12
MHB12-04R	1 1/2	x	1/2	HEX50	27	14
MHB12-06R	1 1/2	x	3/4	HEX50	27	14
MHB12-08R	1 1/2	x	1	HEX50	27	14
MHB12-10R	1 1/2	x	1 1/4	HEX50	27	14
MHB16-06R	2	x	3/4	HEX65	31	16
MHB16-08R	2	x	1	HEX65	31	16
MHB16-10R	2	x	1 1/4	HEX65	31	16
MHB16-12R	2	x	1 1/2	HEX65	31	16

■ 색은 제작용입니다

Male/Female Adapter Type C

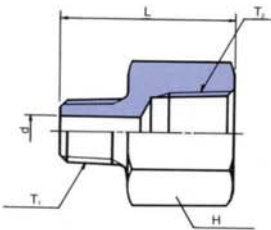

품명	T (PT)	x	T1 (PT)	D	L	H
MHR01-02R	1/8	x	1/4	4	30	HEX22
MHR01-03R	1/8	x	3/8	4	31	HEX24
MHR02-03R	1/4	x	3/8	7	35	HEX24
MHR02-04R	1/4	x	1/2	7	39	HEX32
MHR02-06R	1/4	x	3/4	7	42	HEX36
MHR03-04R	3/8	x	1/2	9	41	HEX32
MHR03-06R	3/8	x	3/4	9	44	HEX36
MHR03-08R	3/8	x	1	9	47	HEX46
MHR04-06R	1/2	x	3/4	12	48	HEX36
MHR04-08R	1/2	x	1	12	52	HEX46
MHR04-10R	1/2	x	1 1/4	12	56	HEX55
MHR06-08R	3/4	x	1	16	55	HEX46
MHR06-10R	3/4	x	1 1/4	16	59	HEX55
MHR06-12R	3/4	x	1 1/2	16	60	HEX65
MHR08-10R	1	x	1 1/4	20	64	HEX55
MHR08-12R	1	x	1 1/2	20	64	HEX65
MHR08-16R	1	x	2	20	69	HEX75
MHR10-12R	1 1/4	x	1 1/2	28	69	HEX65
MHR10-16R	1 1/4	x	2	28	73	HEX75
MHR12-16R	1 1/2	x	2	32	75	HEX75

■ 색은 제작용입니다

Pipe & Tube Clamp

Stainless Steel, Steel

Fix Clamp
Heavy
Standard
Twin



Fix Clamp

*This tbe clamp is used to fix copper piping

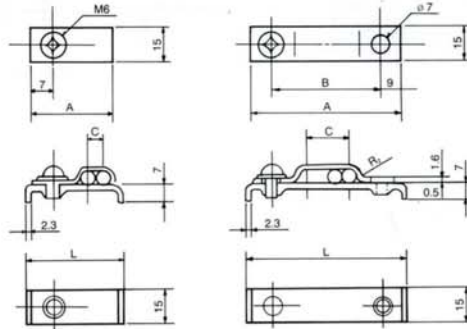

MARK	Type	Tube 외경 & Fix	A	B	C	L	R	
P I X I C	O	A1	○ 6 x 1	25	-	-	40	3
		A2	○ 6 x 2	29	-	6	40	3
		A3	○ 6 x 3	58	40	12	62	3
		A4	○ 6 x 4	66	48	18	70	3
		A5	○ 6 x 5	74	56	24	78	3
		A6	○ 6 x 6	80	62	30	84	3
	O	B1	○ 8 x 1	25	-	-	40	4
		B2	○ 8 x 2	32	-	8	40	4
	Y	B3	○ 8 x 3	66	48	16	70	4
		B4	○ 8 x 4	74	56	24	73	4
		B5	○ 8 x 5	80	62	32	84	4
		B6	○ 8 x 6	90	72	40	94	4
		B7	○ 8 x 7	104	85	48	107	4
		B8	○ 8 x 8	110	92	56	114	4
	O	D1	○ 10 x 1	29	-	-	40	5
	Y	D2	○ 10 x 2	66	48	10	70	5
		D3	○ 10 x 3	74	56	20	78	5
		D4	○ 10 x 4	80	62	30	84	5
	O	E1	○ 12 x 1	32	-	-	40	6
	Y	E2	○ 12 x 2	66	48	12	70	6
		E3	○ 12 x 3	80	62	24	84	6
		E4	○ 12 x 4	90	72	36	94	6
		E5	○ 12 x 5	103	85	48	107	6
		G1	○ 15 x 1	58	40	-	62	7.5
G2		○ 15 x 2	74	56	15	78	7.5	
G3		○ 15 x 3	90	72	30	94	7.5	
G4	○ 15 x 4	103	85	45	107	7.5		

Pipe & Tube Clamp

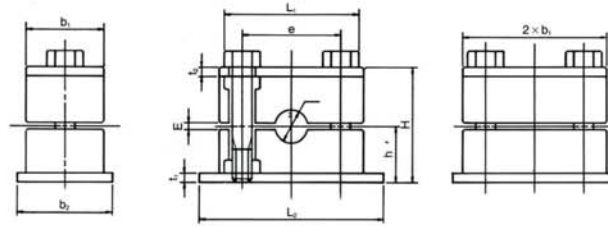

Part Name			Dimension(mm)										Weight	
A	Inch(O.D)	d	L1	b2	t1	L2	b2	t2	H	h	E	e	Bolt	(kg)
		8												
6	1/8	10.5												
		12												
8	1/4	13.8	55	30	7	73	32	8	48	24	2	33	M10 x 45	0.3
		15												
		16												
10	3/8	17.3												
		20												
15	1/2	21.7												
		25	70	30	7	85	32	8	64	32	2	45	M10 x 60	0.5
20	3/4	27.2												
		30												
		32												
25	1	34.0												
		35												
		38	85	30	7	100	32	8	76	38	2	60	M10 x 70	0.6
		40												
32	1 1/4	42.7												
		45												
40	1 1/2	48.6												
		50												
		55												
50	2	60.5	115	45	9	150	50	9	110	55		88	M12 x 110	1.5
		65												
		70												
		73												
65	2 1/2	76.3												
		80	150	60	10	200	65	10	140	73	3	120	M16 x 140	3.0
80	3	89.1												
		100												
90	3 1/4	101.6												
100	4	114.3	205	80	15	270	90	15	200	100	3	168	M20 x 195	7.3
125	5	139.8												
150	6	165.2	245	90	15	310	100	15	230	115	4	206	M24 x 225	9.5
200	8	216.4	320	122	25	380	130	25	320	160	4	265	M30 x 300	23
250	10	267.4												
300	12	318.5	466	160	30	520	170	30	470	235	5	395	M33 x 450	52

Heavy

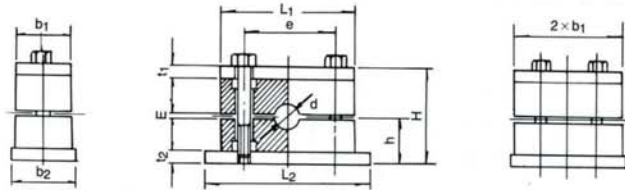
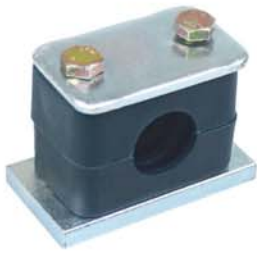

Part Name		Dimension(mm)											Weight	
A	Inch(O.D)	d	L1	b1	t1	L2	b2	t2	H	h	E	e	Bolt	(kg)
		8												
6	1/8	10.5												
		12												
8	1/4	13.8	55	30	8	73	38	8	48	24	2	33	M10 x 45	0.3
		15												
		16												
10	3/8	17.3												
		20												
15	1/2	21.7												
		25	70	30	8	85	38	8	64	32	2	45	M10 x 60	0.5
20	3/4	27.2												
		30												
		32												
25	1	34.0												
		35												
		38	85	30	8	100	38	8	76	38	2	60	M10 x 70	0.6
		40												
32	1 1/4	42.7												
		45												
40	1 1/2	48.6												
		50												
		55												
50	2	60.5	115	45	10	150	50	10	110	55	2	90	M12 x 110	1.5
		65												
		70												
		73												
65	2 1/2	76.3												
		80	152	60	10	200	65	12	140	73	3	122	M16 x 140	3.0
80	3	89.1												
		100												
90	3 1/4	101.6												
100	4	114.3	205	80	15	270	90	15	200	100	3	168	M20 x 195	7.3
125	5	139.8												
150	6	165.2	250	90	15	310	100	15	230	115	4	206	M24 x 225	9.5
200	8	216.4	320	120	25	380	130	25	320	160	4	265	M30 x 300	23
250	10	267.4												
300	12	318.5	466	160	30	520	170	30	470	235	5	395	M33 x 450	52

PIPE & TUBE CLAMP

Standard

*WORKING PRESSURE
70kg/cm² BELOW

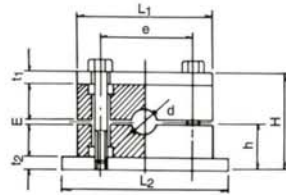

Part Name		Dimension(mm)											Weight	
A	Inch(O.D)	d	L1	b1	t1	L2	b2	t2	H	h	E	e	Bolt	(kg)
		6												
		8	36	30	2	50	40	5	38	20.5	1	20	M6 x 40	0.2
6	1/8	10.5												
		12	38	30	2	50	40	5	38	20.5	1	21	M6 x 40	0.2
8	1/4	13.8												
		15	41	30	2	54	40	5	39	21	1	24	M6 x 40	0.2
		16												
10	3/8	17.3	49	30	2	60	40	5	46	24.5	1	30	M8 x 45	0.2
		20												
15	1/2	21.7	53	30	2	64	40	5	48	25.5	1	34	M8 x 50	0.3
		25												
20	3/4	27.2	59	30	2	70	40	5	52.5	28	1	40	M8 x 50	0.3

OCBS-S



OCN-S



OCR-S

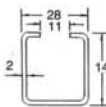

Twin

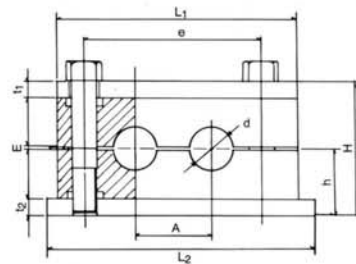

Part Name		Dimension(mm)												
A	Inch(O.D)	d	L1	b1	t1	L2	b2	t2	H	h	E	e	A	Bolt
		6												
		8												
6	1/8	10.5	63	30	2.5	72	38	6	40	15	1.5	45	23	M6 x 40
		12												
8	1/4	13.8												
		15												
		16	78	30	2.5	92	38	6	40	15	1.5	60	26	M8 x 40
10	3/8	17.3												
		20												
15	1/2	21.7	95	30	2.5	110	38	6	48.5	20	1.5	76	38	M8 x 50

YM NIPPLE

One Touch Fitting & Hose

PC Type
 PL Type
 PUC Type
 PUL Type
 PUT Type
 PT Type
 PCF Type
 PLL Type
 PST Type
 PW Type
 PY Type
 PWT Type
 PG Type
 PZA Type
 PMM Type
 ELBOW Type
 FLAT Type
 HVU Type
 PLASTIC Type

Polyretan Hose
 Coil Hose Coupling
 Nylon Tube



Two Touch Fitting (Plastic Type)

CK type
 GCK type
 FCK type



PC Type

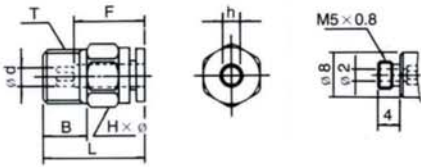

품명	튜브 외경	T (R/PT)	L	B	ød	H x ø	h	F	중량 (g)
PC04-M5	4	M5	22.0	-	-	10x11.0	3	13.5	-
PC04-01	4	1/8	19.0	8	3	10x11.0	3	13.5	10.7
PC04-02	4	1/4	22.0	11	3	14x15.4	3	13.5	14.0
PC06-M5	6	M5	24.0	-	-	12x13.0	5	15.0	-
PC06-01	6	1/8	21.0	8	5	12x13.0	5	15.0	9.6
PC06-02	6	1/4	24.0	11	5	14x15.4	5	15.0	14.1
PC06-03	6	3/8	25.0	12	5	17x18.5	5	15.0	26.2
PC08-01	8	1/8	25.5	8	5	14x15.4	5	16.0	15.1
PC08-02	8	1/4	24.5	11	6	14x15.4	6	16.0	15.2
PC08-03	8	3/8	25.5	12	6	17x18.5	6	16.0	25.7
PC08-04	8	1/2	24.5	15	8	22x24.5	6	16.0	48.0
PC10-01	10	1/8	29.5	8	5	17x18.5	5	19.0	25.7
PC10-02	10	1/4	27.5	11	8	17x18.5	8	19.0	27.3
PC10-03	10	3/8	28.5	12	8	17x18.5	8	19.0	26.1
PC10-04	10	1/2	31.5	15	8	22x24.5	8	19.0	44.7
PC12-02	12	1/4	33.5	11	8	19x21.0	8	20.0	35.0
PC12-03	12	3/8	29.5	12	10	19x21.0	10	20.0	29.3
PC12-04	12	1/2	32.5	15	10	22x24.5	10	20.0	55.3
PC16-03	16	3/8	39.7						
PC16-04	16	1/2	42.2						

PL Type

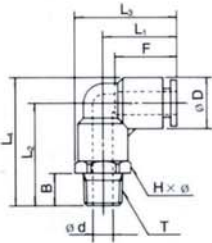

품명	튜브 외경	T (R/PT)	L1	L2	L3	L4	B	øD	ød	H x ø	F	중량 (g)
PL04-M5	4	M5	16.5	20.5	22.0	25.4	-	9.7	-	10x11.0	13.5	4.9
PL04-01	4	1/8	16.5	22.5	22.0	27.4	8	9.7	4	10x11.0	13.5	9.3
PL04-02	4	1/4	16.5	26.5	24.2	31.4	11	9.7	4	14x15.4	13.5	18.2
PL06-M5	6	M5	18.5	22.5	25.0	28.8	-	12.5	-	12x13.0	15.0	5.7
PL06-01	6	1/8	18.5	25.0	25.0	31.3	8	12.5	5	12x13.0	15.0	13.0
PL06-02	6	1/4	18.5	29.0	26.2	35.3	11	12.5	5	14x15.4	15.0	18.4
PL06-03	6	3/8	18.5	30.0	27.8	36.3	12	12.5	5	17x18.5	15.0	26.8
PL08-01	8	1/8	20.5	26.0	28.2	33.3	8	14.5	5	14x15.4	16.0	16.0
PL08-02	8	1/4	20.5	30.0	28.2	37.3	11	14.5	6	17x18.5	16.0	20.2
PL08-03	8	3/8	20.5	31.0	29.8	38.3	12	14.5	6	17x18.5	16.0	27.8
PL08-04	8	1/2	20.5	33.0	32.5	40.4	15	14.5	6	22x24.0	16.0	44.9
PL10-01	10	1/8	24.5	29.0	33.8	37.8	8	17.5	5	17x18.5	19.0	21.9
PL10-02	10	1/4	24.5	33.0	33.8	41.8	11	17.5	7	17x18.5	19.0	27.8
PL10-03	10	3/8	24.5	34.0	33.8	42.8	12	17.5	9	17x18.5	19.0	34.1
PL10-04	10	1/2	24.5	38.0	36.5	46.8	15	17.5	9	22x24.0	19.0	47.9
PL12-02	12	1/4	26.0	35.5	36.5	46.8	15	17.5	9	22x24.0	19.0	47.9
PL12-03	12	3/8	26.0	36.5	36.5	46.5	12	20.0	9	19x21.0	20.0	38.1
PL12-04	12	1/2	26.0	40.5	38.0	50.5	15	20.0	10	22x24.0	20.0	53.3
PL16-03	16	3/8										
PL16-04	16	1/2										

PUC Type



품명	튜브외경	L1	L2	L3	L4	øD	F	중량(g)
PUC0400	4	15.0	30.0	9.7	5.0	9.7	13.5	3.8
PUC0600	6	16.0	33.0	12.5	6.0	12.5	15.0	6.2
PUC0800	8	17.5	35.0	14.5	7.0	14.5	16.0	7.9
PUC1000	10	20.5	41.0	17.5	8.5	17.5	19.0	13.8
PUC1200	12	21.5	43.0	20.0	9.8	20.0	20.0	16.9
PUC1600	16							

PUL Type

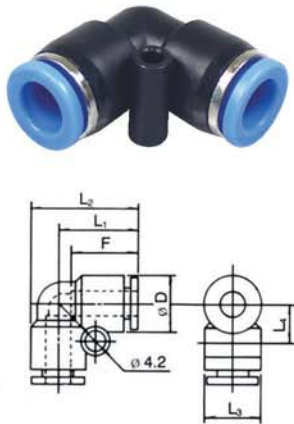

품명	튜브외경	L1	L2	L3	L4	øD	F	중량(g)
PUL0400	4	16.5	21.4	9.7	5.0	9.7	13.5	4.2
PUL0600	6	18.5	24.8	12.5	5.0	9.7	13.5	4.2
PUL0800	8	20.5	27.8	14.5	7.0	14.5	16.0	8.5
PUL1000	10	24.5	33.3	17.5	8.5	17.5	19.0	13.6
PUL1200	12	20.0	36.0	20.0	9.8	20.0	20.0	17.4
PUL1600	16							

PUT Type



품명	튜브외경	L1	L2	L3	L4	L5	øD	F	중량(g)
PUT0400	4	16.5	21.4	9.7	5.0	14.0	9.7	13.5	5.9
PUT0600	6	18.5	24.8	12.5	6.0	17.0	12.5	15.0	9.8
PUT0800	8	20.5	27.8	14.5	7.0	19.0	14.5	16.0	12.2
PUT1000	10	24.5	33.3	17.5	8.5	22.0	17.5	19.0	20.6
PUT1200	12	26.0	36.0	20.0	9.8	24.0	20.0	20.0	24.7
PUT1600	16								

PT Type

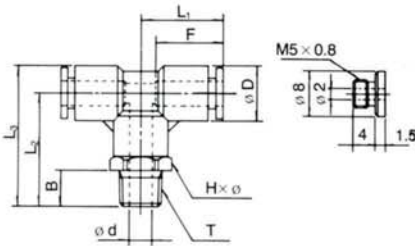

품명	튜브 외경	T (R/PT)	L1	L2	L3	B	øD	ød	H x ø	F	중량 (g)
PT04-M5	4	M5	16.5	20.5	25.4	-	9.7	-	10x11.0	13.5	12.6
PT04-01	4	1/8	16.5	22.5	27.4	8	9.7	4	10x11.0	13.5	11.4
PT04-02	4	1/4	16.5	26.5	31.4	11	9.7	4	14x15.4	13.5	18.2
PT06-M5	6	M5	18.5	22.5	28.8	-	12.5	-	12x13.0	15.0	17.3
PT06-01	6	1/8	18.5	25.0	31.3	8	12.5	5	12x13.0	15.0	15.5
PT06-02	6	1/4	18.5	29.0	35.3	11	12.5	5	14x15.4	15.0	22.3
PT06-03	6	3/8	18.5	30.0	35.3	12	12.5	5	17x18.5	15.0	29.1
PT08-01	8	1/8	20.5	26.0	33.3	8	14.5	5	14x15.4	15.0	29.1
PT08-02	8	1/4	20.5	30.0	37.3	11	14.5	6	14x15.4	16.0	19.5
PT08-03	8	3/8	20.5	31.0	38.3	12	14.5	6	17x18.5	16.0	32.5
PT08-04	8	1/2	20.5	33.0	40.4	15	14.5	6	22x24.0	16.0	44.5
PT10-01	10	1/8	24.5	29.0	37.8	8	17.5	5	17x18.5	19.0	27.2
PT10-02	10	1/4	24.5	33.0	41.8	11	17.5	7	17x18.5	19.0	33.1
PT10-03	10	3/8	24.5	34.0	42.8	12	17.5	9	17x18.5	19.0	39.8
PT10-04	10	1/2	24.5	34.0	42.8	15	17.5	5	22x24.0	19.0	55.0
PT12-02	12	1/4	26.0	35.5	45.5	11	20.0	7	19x21.0	20.0	46.3
PT12-03	12	3/8	26.0	36.5	46.5	12	20.0	9	19x21.0	20.0	46.3
PT12-04	12	1/2	26.0	40.5	50.5	15	20.0	10	22x24.0	20.0	60.1

PCF Type

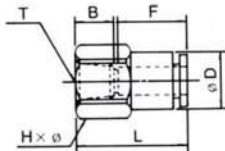

품명	튜브 외경	T (RC/PT)	L	B	øD	H x ø	F	중량 (g)
PCF04-01	4	1/8	3.0	9.0	10.0	14x15.4	13.5	16.5
PCF04-02	4	1/4	27.0	11.0	10.0	17x18.5	13.5	24.3
PCF06-01	6	1/8	24.5	9.0	12.0	14x15.4	15.0	18.4
PCF06-02	6	1/4	29.0	11.0	12.0	17x18.5	15.0	42.2
PCF06-03	6	3/8	30.0	12.0	12.0	19x21.0	15.0	27.5
PCF08-01	8	1/8	29.5	9.0	14.0	17x18.5	16.0	27.0
PCF08-02	8	1/4	30.0	13.0	14.0	17x18.5	16.0	28.8
PCF08-03	8	3/8	30.5	13.5	14.0	22x24.5	16.0	48.7
PCF10-01	10	1/8	30.5	9.0	17.0	17x18.5	19.0	32.5
PCF10-02	10	1/4	33.0	13.0	17.0	17x18.5	19.0	30.8
PCF10-03	10	3/8	33.5	13.5	17.0	22x24.5	19.0	52.2
PCF12-02	12	1/4	34.0	13.0	19.0	19x21.0	20.0	42.2
PCF12-03	12	3/8	34.5	13.5	17.0	22x24.5	20.0	35.3
PCF12-04	12	1/2	37.5	15.0	19.0	24x27.0	20.0	56.0

PLL Type

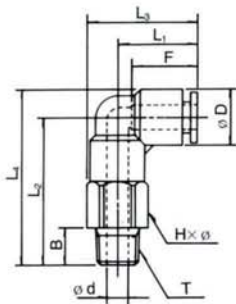

품명	튜브 외경	T (R/PT)	L1	L2	L3	L4	B	øD	ød	H x ø	F	중량 (g)
PLL04-M5	4	M5	16.0	34.5	20.5	39.5	4	9.7	2	8x9.0	13.5	18.3
PLL04-01	4	1/8	16.5	32.5	22.0	37.4	8	9.7	4	10x11.0	13.5	17.3
PLL04-02	4	1/4	16.5	36.5	24.2	41.4	11	9.7	4	14x15.4	13.5	32.5
PLL06-M5	6	M5	17.0	34.5	21.5	41.0	4	12.5	2	8x9.0	15.0	13.5
PLL06-01	6	1/8	18.5	37.0	25.0	43.3	8	12.5	5	12x13.0	15.0	25.8
PLL06-02	6	1/4	18.5	41.0	26.2	47.3	11	12.5	5	14x15.4	15.0	36.3
PLL06-03	6	3/8	18.5	42.0	27.8	48.3	12	12.5	5	17x18.5	15.0	69.3
PLL08-01	8	1/8	20.5	40.0	28.2	47.3	8	14.5	5	14x15.4	16.0	36.0
PLL08-02	8	1/4	20.5	40.0	28.2	51.3	11	14.5	6	14x15.4	16.0	42.7
PLL08-03	8	3/8	20.5	45.0	29.8	52.3	12	14.5	6	17x18.5	16.0	74.6
PLL08-04	8	1/2	20.5	48.0	32.5	55.3	15	14.5	6	22x24.0	16.0	124.0
PLL10-01	10	1/8	24.5	46.0	33.8	54.8	8	17.5	5	17x18.5	19.0	72.4
PLL10-02	10	1/4	24.5	50.0	33.8	58.8	11	17.5	7	17x18.5	19.0	72.4
PLL10-03	10	3/8	24.5	51.0	33.8	59.8	12	17.5	9	17x18.5	19.0	84.6
PLL10-04	10	1/2	24.5	55.0	36.5	63.8	15	17.5	9	22x24.0	19.0	100.2
PLL12-02	12	1/4	26.0	58.0	36.5	68.0	11	20.0	7	19x21.0	20.0	89.4
PLL12-03	12	3/8	26.0	59.0	36.5	69.0	12	20.0	9	19x21.0	20.0	89.4
PLL12-04	12	1/2	26.0	62.0	38.0	72.0	15	20.0	10	22x24.0	20.0	228.8

PST Type

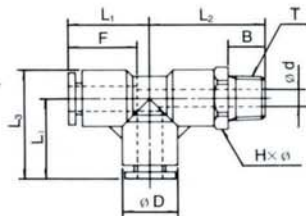

품명	튜브 외경	T (R/PT)	L1	L2	L3	B	øD	ød	H x ø	F	중량 (g)
PST04-M5	4	M5	16.5	20.5	21.4	4	9.7	2	10x11.0	13.5	11.0
PST04-01	4	1/8	16.5	22.5	21.4	8	9.7	4	10x11.0	13.5	11.7
PST04-02	4	1/4	16.5	26.5	21.4	11	9.7	4	14x15.4	13.5	19.0
PST06-M5	6	M5	18.5	22.5	24.8	4	12.5	2	10x11.0	15.0	15.8
PST06-01	6	1/8	18.5	25.0	24.8	8	12.5	5	12x13.0	15.0	16.2
PST06-02	6	1/4	18.5	29.0	24.8	11	12.5	5	14x15.4	15.0	21.4
PST06-03	6	3/8	18.5	30.0	24.8	12	12.5	5	17x18.5	15.0	29.3
PST08-01	8	1/8	20.5	26.0	27.8	8	14.5	5	14x15.4	16.0	19.3
PST08-02	8	1/4	20.5	30.0	27.8	11	14.5	7	14x15.4	16.0	24.5
PST08-03	8	3/8	20.5	31.0	27.8	12	14.5	7	17x18.5	16.0	33.5
PST08-04	8	1/2	20.5	34.0	27.8	15	14.5	7	22x24.0	16.0	50.5
PST10-01	10	1/8	24.5	29.0	33.3	8	17.5	5	17x18.5	19.0	28.9
PST10-02	10	1/4	24.5	33.3	33.3	11	17.5	7	17x18.5	19.0	34.0
PST10-03	10	3/8	24.5	34.0	33.3	12	17.5	9	17x18.5	19.0	40.9
PST10-04	10	1/2	24.5	38.0	33.3	15	17.5	9	17x18.5	19.0	54.3
PST12-02	12	1/4	26.0	35.5	36.0	11	20.0	7	19x21.0	20.0	40.0
PST12-03	12	3/8	26.0	36.5	36.0	12	20.0	9	19x21.0	20.0	46.0
PST12-04	12	1/2	26.0	40.5	36.0	15	20.0	10	22x24.0	20.0	60.3

PW Type

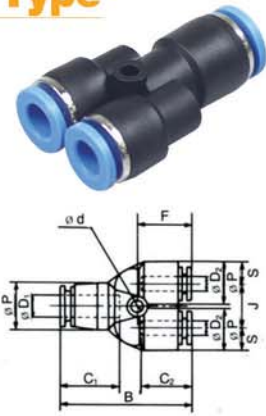

품명	튜브 외경	øD2	B	C1	C2	ød	F	J	øP	S	중량 (g)
PW06-04	6	4	37.0	16.5	15.0	3	15	12	13.0	6.0	7.0
PW08-06	8	6	41.5	17.5	16.5	3	17	14	15.0	7.0	10.0
PW10-06	10	6									
PW10-08	10	8	47.5	20.0	17.5	4	19	18	18.0	8.5	16.0
PW12-08	12	8									
PW12-10	12	10	54.5	23.5	20.0	4	22	20	21.5	10.5	25.0

PY Type

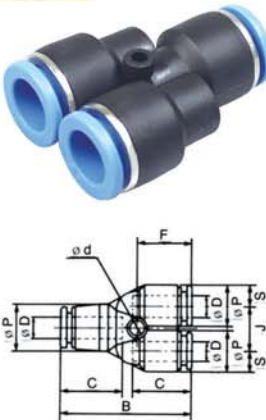

품명	튜브 외경	B	C	ød	F	J	øP	S	중량 (g)
PY0400	4	32.5	15.0	3.3	12.5	11	10	5.0	5
PY0600	6	37.0	16.5	3.2	15.4	12	13	6.0	8
PY0800	8	41.5	17.5	3.2	17.0	14	15	7.0	11
PY1000	10	48.0	20.0	4.2	19.5	18	18	8.7	19
PY1200	12	55.0	23.5	4.2	22.0	20	20	10.5	28
PY1600									

PWT Type

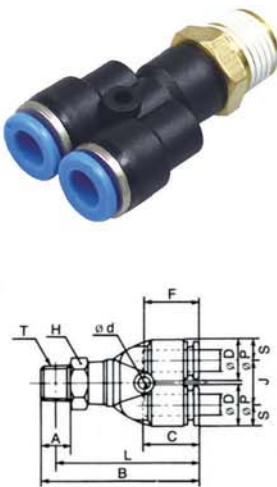

품명	튜브 외경	T (R/PT)	A	B	C	H	J	L	øP	S	중량 (g)
PWT04-M5	4	M5	3.5	42.5	15.0	10	11	39.0	10.0	5.0	11
PWT04-01	4	1/8	8.0	40.1	15.0	10	11	36.5	10.0	5.0	15
PWT04-02	4	1/4	11.0	43.5	15.0	14	11	37.5	10.0	5.0	23
PWT06-M5	6	M5	3.5	41.0	16.5	12	12	37.5	13.0	6.0	13
PWT06-01	6	1/8	8.0	44.0	16.5	12	12	40.0	13.0	6.0	18
PWT06-02	6	1/4	11.0	47.0	16.5	14	12	41.0	13.0	6.0	25
PWT06-03	6	3/8	12.0	49.0	16.5	17	12	42.0	13.0	6.0	38
PWT08-01	8	1/8	8.0	48.0	17.5	14	14	44.0	15.0	7.0	21
PWT08-02	8	1/4	11.0	51.0	17.5	14	14	45.0	15.0	7.0	28
PWT08-03	8	3/8	12.0	52.0	17.5	17	14	46.5	15.0	7.0	40
PWT08-04	8	1/2	15.0	55.0	17.5	22	14	47.0	15.0	7.0	51
PWT10-01	10	1/8	8.0	55.0	20.5	17	18	51.0	18.0	8.5	30
PWT10-02	10	1/4	11.0	58.0	20.5	17	18	52.0	18.0	8.5	39
PWT10-03	10	3/8	12.0	59.0	20.5	17	18	52.5	18.0	8.5	48
PWT10-04	10	1/2	15.0	62.0	20.5	21	18	54.0	18.0	8.5	71
PWT12-02	12	1/4	11.0	63.5	23.5	21	20	57.5	21.5	10.5	57
PWT10-03	12	3/8	12.0	64.5	23.5	21	20	58.0	21.5	10.5	58
PWT10-04	12	1/2	15.0	67.5	23.5	21	20	59.5	21.5	10.5	76

PG Type

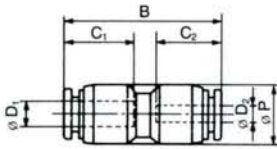

품 명	튜브외경		B	C1	C2	øP	중량 (g)
	D1	D2					
PG06-04	6	4	37.0	16.5	15.0	14.5	10
PG08-06	8	6	37.0	17.5	16.5	14.5	10
PG10-06	10	6					
PG10-08	10	8	42.5	20.0	17.5	17.5	15
PG12-08	12	8					
PG12-10	12	10	53.0	23.5	20.0	21.0	24

PZA Type

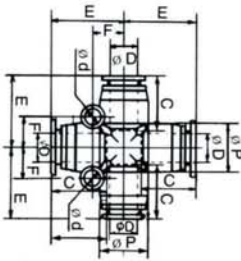

품 명	튜브 외경	C	ød	E	F	øP	중량 (g)
PZA0400	4	13.5	4.2	16.5	5.0	9.7	4
PZA0600	6	15.0	4.2	18.5	6.0	12.5	4
PZA0800	8	16.0	4.2	20.5	7.0	14.5	5
PZA1000	10	19.0	4.2	24.5	8.5	17.5	6
PZA1200	12	20.0	4.2	26.0	9.8	20.0	7

PMM Type

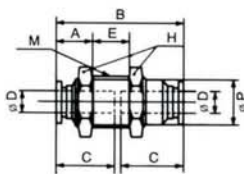

품 명	튜브 외경	A	B	C	E	H	M	øP	중량 (g)
PMM0400	4	9.0	31.0	15.0	8	14	M12X1	11.0	12
PMM0600	6	9.5	34.5	16.5	11	17	M14X1	12.5	16
PMM0800	8	9.0	36.5	17.5	14	19	M16X1	14.5	26
PMM1000	10	11.0	41.0	20.0	14	24	M20X1	18.5	38
PMM1200	12	11.0	48.0	23.5	18	27	M22X1	20.5	48

ELBOW Type

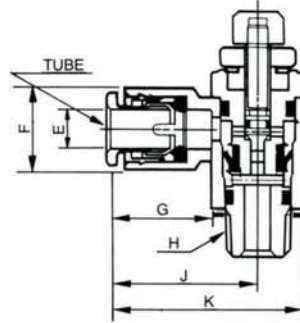

품명	ØD	R	ØP	A	B	C	E	F	G	H	I	ØJ	K	L	M	X	Y	W.G(g)	Q'ty/ Inbox
NSE 04-M5	4	M5	9	3.5	29.5	14.5	19.1	6.5	4	8	9.1	10.4	19.5	5	2.5	8.6	10.8	8	100
NSE 04-01	4	R1/8	9	7.7	40.1	14.5	20.9	7	4	10	12.2	14.4	25.6	10.5	3.5	8.6	10.8	17.2	50
NSE 04-02	4	R1/4	9	11.2	48	14.5	22.8	7	6	14	12	18.4	31.9	11.1	3.5	8.6	10.8	34.4	50
NSE 06-M5	6	M5	11.2	3.5	29.5	15.5	21	7.7	4	8	9.1	10.4	19.5	5	2.5	8.6	10.8	9.1	100
NSE 06-01	6	R1/8	11.2	7.7	40.1	15.5	22	7	4	10	12.2	14.4	25.6	10.5	3.5	11	13	17.9	50
NSE 06-02	6	R1/4	11.2	11.2	48	15.5	24	7	6	14	12	18.4	31.9	11.1	3.5	11	13	35.1	50
NSE 06-03	6	R3/8	11.2	13.3	54.2	15.5	26	8.7	5	19	15.7	22	37.2	12	3.5	11	13	62.5	25
NSE 08-01	8	R1/8	13.6	7.7	40.1	17.8	25.1	8	4	10	12.2	14.4	25.6	10.5	3.5	13	15	19	50
NSE 08-02	8	R1/4	13.6	11.2	48	17.8	27.6	8.1	6	14	12	18.4	31.9	11.1	3.5	13	15	36.1	50
NSE 08-03	8	R3/8	13.6	13.3	54.2	17.8	28.6	8.1	5	19	15.7	22	37.2	12	3.5	13	15	63.5	25
NSE 08-04	8	R1/2	13.6	16.5	59.8	17.8	31.6	8.4	5.5	24	18	28	42.8	12	3.5	13	15	94	20
NSE 10-02	10	R1/4	16.3	11.2	48	19.4	29.6	9.6	6	14	12	18.4	31.9	11.1	3.5	16	18.5	38.9	25
NSE 10-03	10	R3/8	16.3	13.3	54.2	19.4	30	9.7	5	19	15.7	22	37.2	12	3.5	16	18.5	67.8	25
NSE 10-04	10	R1/2	16.3	16.5	59.8	19.4	32.9	10	5.5	24	18	28	42.8	12	3.5	16	18.5	98.7	20
NSE 12-02	12	R1/4	19.7	11.2	48	22.4	33.9	11.3	6	14	12	18.4	31.9	11.1	3.5	19.5	22.5	42.5	25
NSE 12-03	12	R3/8	19.7	13.3	54.2	22.4	35.9	11.4	5	19	15.7	22	37.2	12	3.5	19.5	22.5	70.6	25
NSE 12-04	12	R1/2	19.7	16.5	59.8	22.4	38.9	11.7	5.5	24	18	28	42.8	12	3.5	19.5	22.5	100.4	20

SPEED CONTROL

FLAT Type

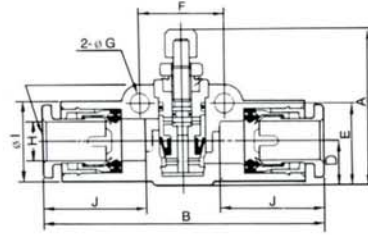

품명	ØD	ØP	A	B	C	E	F	G	I	J	L	M	Ød	X	Y	W.G(g)	Q'ty/ Inbox
NSF 04	4	9	11	38.8	14.5	28.7	6.5	6.5	20	14	5	2.5	3.2	8.6	10.8	11.5	50
NSF 06	6	11.2	15	46.7	15.5	40.9	8.5	10.9	28	20	9.5	3.5	4.2	11	13	27.6	25
NSF 08	8	13.6	18	53	17.8	46.2	9.5	12	30	22	10.2	3.5	4.2	13	15	40.4	25
NSF 10	10	16.3	21	60.6	19.4	52.5	11	12	34	26	11.5	3.5	4.2	16	18.5	66.4	20
NSF 12	12	19.7	28	73.8	22.4	55.6	13	16	40	32	11.5	3.5	4.2	19.5	22.5	110.6	12

HVU Type

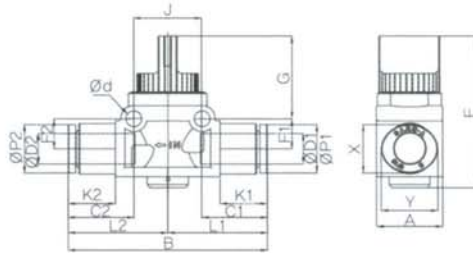

품명	ØD1	ØD2	ØP1	ØP2	A	B	C1	C2	E	F1	F2	G	L1	L2	J	K1	K2	Ød	X	Y	W.G(g)	Q'ty/ Inbox
HVFF 04-04	4	4	9	9	17.6	43.2	14.5	14.5	40.7	10.3	5.7	22.2	21.6	21.6	18.2	7.6	7.6	4.2	8.6	10.8	14	25
HVFF 06-06	6	6	11.2	11.2	17.6	48.9	15.5	15.5	40.7	8	8	22.2	24.5	24.5	18.2	10.5	10.5	4.2	11	13	15.6	25
HVFF 08-06	8	6	13.6	11	17.6	52.6	17.8	17	40.7	8	8	22.2	26.6	26	18.2	12.6	12	4.2	13	15	17.6	25
HVFF 08-08	8	8	13.6	13.6	17.6	53.2	17.8	17.8	40.7	8	8	22.2	26.6	26.6	18.2	12.6	12.6	4.2	13	15	17.6	25
HVFF 10-10	10	10	16.3	16.3	21.2	61	19.4	19.4	40.9	10.1	10.1	20.1	30.5	30.5	24	13.5	13.5	4.2	16	18.5	26.5	20
HVFF 12-10	12	10	19.7	16.3	21.2	65.8	22.4	21.4	40.9	10.1	10.1	20.1	33.4	32.5	24	16.4	15.4	4.2	19.5	22.5	33	16
HVFF 12-12	12	12	19.7	19.7	21.2	66.8	22.4	22.4	40.9	10.1	10.1	20.1	33.4	33.4	24	16.4	16.4	4.2	19.5	22.5	33	16

Plastic Type(ST-01 ~ ST-06)



품명		T(R/PT)	A	B	C	D	E	F
ST	01	1/8	37	∅10	26	8	5.5	3
ST	02	1/4	64	∅22	51	10	12	3
ST	03	3/8	85	∅25	68	14	14	3
ST	04	1/2	95	∅30	75	16	19	4
ST	06	3/4	100	∅40	71	13	16	32
ST	08	1	120	∅48	87	14	19	36

SL



품명		R	A	B	L	D	H	W.G (g)	Q'ty/Inbox
SL	M5	M5	4	3	20.7	4	9	3	100
SL	01	R1/8	7	3.5	24.5	8	12	6	100
SL	02	R1/4	9.5	4	31.5	10	15	13	50
SL	03	R3/8	10.5	5	39.9	12	19	22	50
SL	04	R1/2	12	6	47.3	15	22	37	25
SL	06	R3/4	12	6.5	55.8	19	27	55	20
SL	08	R1	14.5	7	70.5	32	36	122.5	8

SM



품명		R	A	B	L	H	W.G (g)	Q'ty/Inbox
SM	M5	M5	4	3	8.5	8	1	100
SM	01	R1/8	7	3.5	11.5	12	5.5	100
SM	02	R1/4	9.5	4	15	15	10.5	100
SM	03	R3/8	10.5	5	17	19	17	50
SM	04	R1/2	12	6	20	22	29	25
SM	06	R3/4	12	6.5	20.5	27	40	25
SM	08	R1	14.5	7	24.5	36	75	15

Polyuretan Hose



품명	튜브규격(mm)			상용압력 (kgf/cm ²)	파괴압력 (kgf/cm ² , 20℃)	최소곡률반경 (mm)	중량 (g/m)	색상
	외경	내경	두께					
PU-04020	4	2.0	1.00	4	30	10	12	투명
PU-04025	4	2.5	0.75	4	30	10	10	흑색
PU-06040	6	4.0	1.00	4	30	15	20	적색
PU-08050	8	5.0	1.50	4	30	23	40	청색
PU-08055	8	5.5	1.25	4	30	23	33	황색
PU-10065	10	6.5	1.75	4	30	30	56	녹색
PU-12080	12	8.0	2.00	4	30	35	76	백색
PU-12090	12	9.0	1.50	4	30	35	67	

Coil Hose Coupling

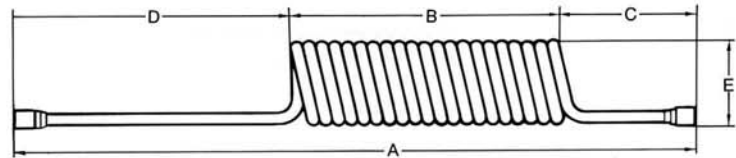
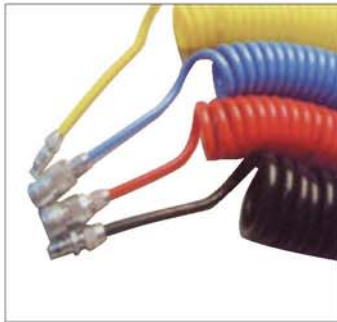

품명	튜브규격 (mm) (mm) (m)	유효길이 (m)	총길이 (m)	상용압력 (kg/cm ²)	A	B	C	D	E
UC-0604-50	6 x 4 x 5	4.0	5.0	9.9	606	300	06	100	30
UC-0805-50	8 x 5 x 5	4.0	5.0	9.9	905	500	305	100	34
UC-0805-75	8 x 5 x 7.5	6.0	7.5	9.9	1090	500	490	100	34
UC-0805-100	8 x 5 x 10	8.0	10.0	9.9	1400	500	800	100	34
UC-1065-50	10 x 6.5 x 5	4.0	5.0	9.9	1000	500	400	100	42
UC-1065-75	10 x 6.5 x 7.5	6.0	7.5	9.9	1235	500	635	100	42
UC-1065-100	10 x 6.5 x 10	8.0	10.0	9.9	1400	500	800	100	42
UC-1208-50	12 x 8 x 5	4.0	5.0	9.9	990	500	390	100	59
UC-1208-75	12 x 8 x 7.5	6.0	7.5	9.9	1190	500	590	100	59
UC-1208-100	12 x 8 x 10	8.0	10.0	9.9	1380	500	780	100	59

Nylon Tube



품 명	튜브규격(mm)			상용압력 (kgf/cm ²)	파괴압력 (kgf/cm ² , 20°C)	최소곡률반경 (mm)	중량 (g/m)
	외경	내경	두께				
N-04020	4	2.0	1.00	9.9	150	10	11
N-04025	4	2.5	0.75	9.9	60	20	8
N-06040	6	4.0	1.00	9.9	90	20	17
N-08060	8	6.0	1.00	9.9	60	30	23
N-10080	10	8.0	1.00	9.9	50	35	29
N-12090	12	9.0	1.50	9.9	60	45	51
N-16130	16	13.0	1.50	9.9	50	100	70

CK Type



(Plastic)

품 명	튜브규격		관접속구경 (R/PT)	유효 직경	B	L	SW	SW ₁
	외경	내경						
CK04-01	4	2.5	1/8	2.0	7.0	24.0	13	8
CK06-01	6	4.0	1/8	3.0	7.0	28.0	13	12
CK06-02	6	4.0	1/4	3.0	9.4	31.6	17	12
CK08-01	8	5.0	1/8	4.0	9.4	31.7	17	14
CK08-02	8	5.5	1/4	4.0	9.4	31.7	17	14
CK08-03	8	5.5	3/8	4.0	11.3	34.0	19	14
CK10-02	10	6.5	1/4	5.0	9.5	31.0	17	17
CK10-03	10	6.5	3/8	5.0	11.5	34.2	19	17
CK12-02	12	9.0	1/4	6.5	9.5	38.2	19	19
CK12-03	12	9.0	3/8	6.5	11.5	40.7	19	19

GCK Type

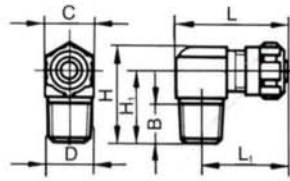

(Plastic)

품명	튜브규격		관접속구경 (R/PT)	유효 직경	B	C	H	H1	L	L1
	외경	내경								
GCK04-01	4	2.5	1/8	2.0	8.0	11	22.5	16.5	25.5	19.5
GCK06-01	6	4.0	1/8	3.0	8.0	14	24.5	17.5	28.0	22.0
GCK06-02	6	4.0	1/4	3.0	11.0	14	27.5	20.5	31.5	24.0
GCK08-02	8	5.5	1/4	4.0	10.5	14	27.5	20.5	31.5	24.0
GCK08-03	8	5.5	3/8	4.0	10.5	19	28.0	21.0	35.0	25.5
GCK10-02	10	6.5	1/4	5.0	11.0	16	28.5	20.5	31.5	24.0
GCK10-03	10	6.5	3/8	5.0	10.5	19	28.0	21.0	35.0	25.5
GCK12-03	12	9.0	3/8	6.5	10.5	19	33.0	23.5	41.5	32.0

FCK Type

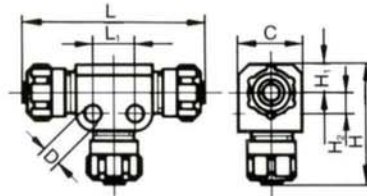

(Plastic)

품명	튜브규격		유효 직경	D	C	H	H1	H2	L	L1
	외경	내경								
FCK-04	4	2.5	2.0	3.0	11.0	25.0	4	5	42	10
FCK-06	6	4.0	3.0	4.3	15.0	32.0	6	6	52	12
FCK-08	8	5.5	4.0	4.3	18.0	34.0	8	6	52	12
FCK-10	10	6.5	5.0	4.3	20.5	36.5	10	8	53	13
FCK-12	12	9.0	6.5	4.3	22.0	38.0	12	9	54	14

Two Touch PE Nipple(Brass)

Male Straight
Male Elbow
Male Branch Tee
Union Straight
Union Tee



Male Straight

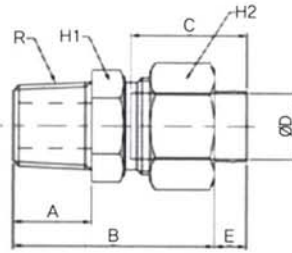

(mm)

품 명	A	B	C	E	H1	H2	R	ØD	W.G(g)	Q'ty/ Inbox
YCIN 04-02-01	11	27.5	13.6	4.55	10	10	R1/8	4.2	15	100
YCIN 04-02-02	12	29	13.6	4.55	14	10	R1/4	4.2	19	100
YCIN 06-04-01	11	27.8	13.8	4.5	10	12	R1/8	6.2	15	100
YCIN 06-04-02	12	29.3	13.8	4.5	14	12	R1/4	6.2	20	50
YCIN 06-04-03	13	30.3	13.8	4.5	17	12	R3/8	6.2	30	25
YCIN 08-05-01	11	28.7	15.6	4.4	12	14	R1/8	8.2	18	50
YCIN 08-05-02	12	30.2	15.6	4.4	14	14	R1/4	8.2	23	50
YCIN 08-05-03	13	31.2	15.6	4.4	17	14	R3/8	8.2	33	50
YCIN 08-06-01	11	28.7	15.6	4.4	12	14	R1/8	8.2	18	50
YCIN 08-06-02	12	30.2	15.6	4.4	14	14	R1/4	8.2	22	50
YCIN 08-06-03	13	31.2	15.6	4.4	17	14	R3/8	8.2	30	50
YCIN 10-6.5-02	12	30.9	17.8	4.9	15	17	R1/4	10.2	28	50
YCIN 10-6.5-03	13	31.9	17.8	4.9	17	17	R3/8	10.2	34	50
YCIN 10-6.5-04	18	36.9	17.8	4.9	22	17	R1/2	10.2	63	25
YCIN 10-08-02	12	30.9	17.8	4.9	15	17	R1/4	10.2	33	50
YCIN 10-08-03	13	31.9	17.8	4.9	17	17	R3/8	10.2	34	50
YCIN 10-08-04	18	36.9	17.8	4.9	22	17	R1/2	10.2	62	25
YCIN 12-08-02	12	31.4	18.8	5.4	17	19	R1/4	12.2	33	50
YCIN 12-08-03	13	32.4	18.8	5.4	17	19	R3/8	12.2	37	25
YCIN 12-08-04	18	37.4	18.8	5.4	22	19	R1/2	12.2	66	25
YCIN 12-09-02	12	31.4	18.8	5.4	17	19	R1/4	12.2	34	50
YCIN 12-09-03	13	32.4	18.8	5.4	17	19	R3/8	12.2	38	25
YCIN 12-09-04	18	37.4	18.8	5.4	22	19	R1/2	12.2	66	25

Male Elbow

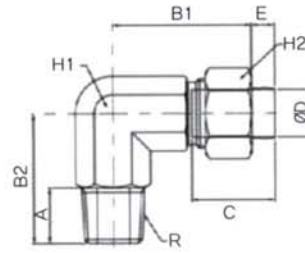

(mm)

품 명	A	B1	B2	C	E	H1	H2	R	ØD	W.G(g)	Q'ty/ Inbox
YLIN 04-02-01	11	20.05	19	13.6	4.55	10	10	R1/8	4.2	18	100
YLIN 04-02-02	12	22.05	22	13.6	4.55	12	10	R1/4	4.2	28	50
YLIN 06-04-01	11	20.3	19	13.8	4.5	10	12	R1/8	6.2	20	50
YLIN 06-04-02	12	22.3	22	13.8	4.5	12	12	R1/4	6.2	26	50
YLIN 06-04-03	13	28.3	29	13.8	4.5	14	12	R3/8	6.2	48	25
YLIN 08-05-01	11	23.2	21	15.6	4.4	12	14	R1/8	8.2	29	50
YLIN 08-05-02	12	23.2	22	15.6	4.4	12	14	R1/4	8.2	31	50
YLIN 08-05-03	13	29.2	29	15.6	4.4	14	14	R3/8	8.2	47	25
YLIN 08-06-01	11	23.2	21	15.6	4.4	12	14	R1/8	8.2	29	50
YLIN 08-06-02	12	23.2	22	15.6	4.4	12	14	R1/4	8.2	30	50
YLIN 08-06-03	13	29.2	29	15.6	4.4	14	14	R3/8	8.2	48	25
YLIN 10-6.5-02	12	29.9	28	17.8	4.9	14	17	R1/4	10.2	55	25
YLIN 10-6.5-03	13	29.9	29	17.8	4.9	14	17	R3/8	10.2	53	25
YLIN 10-6.5-04	18	29.9	34	17.8	4.9	14	17	R1/2	10.2	62	25
YLIN 10-08-02	12	29.9	28	17.8	4.9	14	17	R1/4	10.2	53	25
YLIN 10-08-03	13	29.9	29	17.8	4.9	14	17	R3/8	10.2	52	25
YLIN 10-08-04	18	29.9	34	17.8	4.9	14	17	R1/2	10.2	61	25
YLIN 12-08-02	12	30.9	28	18.8	5.4	14	19	R1/4	12.2	57	25
YLIN 12-08-03	13	30.9	29	18.8	5.4	14	19	R3/8	12.2	56	25
YLIN 12-08-04	18	30.9	34	18.8	5.4	14	19	R1/2	12.2	76	25
YLIN 12-09-02	12	30.9	28	18.8	5.4	14	19	R1/4	12.2	56	25
YLIN 12-09-03	13	30.9	29	18.8	5.4	14	19	R3/8	12.2	59	25
YLIN 12-09-04	18	30.9	34	18.8	5.4	14	19	R1/2	12.2	74	25

Male Branch Tee

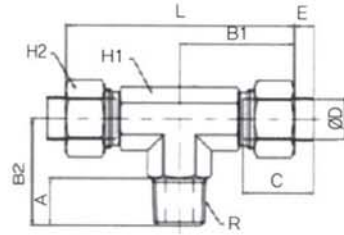

(mm)

품 명	A	B1	B2	C	E	L	H1	H2	R	ØD	W.G(g)	Q'ty/ Inbox
YTIN 04-02-01	11	20.05	19	13.6	4.55	40.1	10	10	R1/8	4.2	25	100
YTIN 04-02-02	12	22.05	22	13.6	4.55	44.1	12	10	R1/4	4.2	33	100
YTIN 06-04-01	11	20.3	19	13.8	4.5	40.6	10	12	R1/8	6.2	30	50
YTIN 06-04-02	12	22.3	22	13.8	4.5	44.6	12	12	R1/4	6.2	41	50
YTIN 06-04-03	13	27.3	28	13.8	4.5	54.6	14	12	R3/8	6.2	67	25
YTIN 08-05-01	11	23.2	21	15.6	4.4	46.4	12	14	R1/8	8.2	43	50
YTIN 08-05-02	12	23.2	22	15.6	4.4	46.4	12	14	R1/4	8.2	44	50
YTIN 08-05-03	13	28.2	28	15.6	4.4	56.4	14	14	R3/8	8.2	67	50
YTIN 08-06-01	11	23.2	21	15.6	4.4	46.4	12	14	R1/8	8.2	42	50
YTIN 08-06-02	12	23.2	22	15.6	4.4	46.4	12	14	R1/4	8.2	44	50
YTIN 08-06-03	13	28.2	28	15.6	4.4	56.4	14	14	R3/8	8.2	66	25
YTIN 10-6.5-02	12	28.9	27	17.8	4.9	57.8	14	17	R1/4	10.2	60	25
YTIN 10-6.5-03	13	28.9	28	17.8	4.9	57.8	14	17	R3/8	10.2	64	25
YTIN 10-6.5-04	18	29.7	32	17.8	4.9	59.4	18	17	R1/2	10.2	77	20
YTIN 10-08-02	12	28.9	27	17.8	4.9	57.8	14	17	R1/4	10.2	58	25
YTIN 10-08-03	13	28.9	28	17.8	4.9	57.8	14	17	R3/8	10.2	63	25
YTIN 10-08-04	18	29.7	32	17.8	4.9	59.4	18	17	R1/2	10.2	76	20
YTIN 12-08-02	12	29.4	27	18.8	5.4	58.8	14	19	R1/4	12.2	62	25
YTIN 12-08-03	13	29.4	28	18.8	5.4	58.8	14	19	R3/8	12.2	78	25
YTIN 12-08-04	18	30.2	32	18.8	5.4	60.4	18	19	R1/2	12.2	82	20
YTIN 12-09-02	12	29.4	27	18.8	5.4	58.8	14	19	R1/4	12.2	61	25
YTIN 12-09-03	13	29.4	28	18.8	5.4	58.8	14	19	R3/8	12.2	78	25
YTIN 12-09-04	18	30.2	32	18.8	5.4	60.4	18	19	R1/2	12.2	83	20

Union Straight

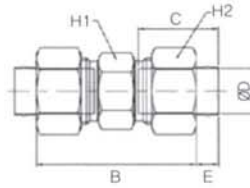

(Brass)

품 명	B	C	E	H1	H2	ØD	W.G(g)	Q'ty/ Inbox
YUCIN 04-02	31.1	13.6	4.55	10	10	4.2	13	100
YUCIN 06-04	31.6	13.8	4.5	10	12	6.2	20	50
YUCIN 08-05	33.4	15.6	4.4	12	14	8.2	25	50
YUCIN 08-06	33.4	15.6	4.4	12	14	8.2	28	50
YUCIN 10-6.5	35.8	17.8	4.9	15	17	10.2	40	50
YUCIN 10-08	35.8	17.8	4.9	15	17	10.2	39	50
YUCIN 12-08	36.8	18.8	5.4	17	19	12.2	46	25
YUCIN 12-09	36.8	18.8	5.4	17	19	12.2	48	25

Union Tee

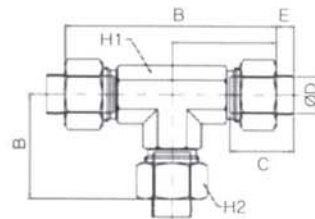

(Brass)

품 명	B1	B2	L	C	E	H1	H2	ØD	W.G(g)	Q'ty/ Inbox
YUTIN 04-02	20.05	20.05	40.1	13.6	4.55	10	10	4.2	25	50
YUTIN 06-04	20.3	20.3	40.6	13.8	4.5	10	12	6.2	36	50
YUTIN 08-05	23.0	23.2	46.4	15.6	4.4	12	14	8.2	51	25
YUTIN 08-06	23.2	23.2	46.4	15.6	4.4	12	14	8.2	50	25
YUTIN 10-6.5	28.9	28.9	57.8	17.8	4.9	14	17	10.2	76	25
YUTIN 10-08	28.9	28.9	57.8	17.8	4.9	14	17	10.2	75	25
YUTIN 12-08	29.4	29.4	58.8	18.8	5.4	14	19	12.2	94	20
YUTIN 12-09	29.4	29.4	58.8	18.8	5.4	14	19	12.2	93	20

Coupling

Stainless Steel, Steel, Brass

Ace Coupler
Nut Coupler
TSP Coupler
SP Coupler
HSP Coupler



Ace Coupler

코르크(CORK)·C

호스 접속용 (PH형)



품 명	관접속구경 (호스닛볼)	치수(mm)		
		Lp	A	∅
PH22	1/4	57	30	16
PH23	3/8	61	34	16
PH24	1/2	63	36	20
PH44	1/2	66	36	22
PH46	3/4	77	45	30
PH48	1	85	55	34

숫나사 접속용 (PM형)

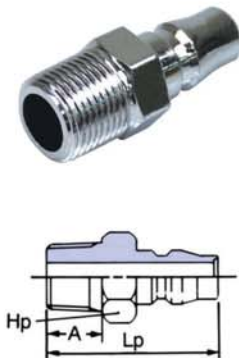

품 명	관접속구경 (R/PT)	치수(mm)		
		Lp	A	Hp
PM21	1/8	37	10	H14
PM22	1/4	41	13	H14
PM23	3/8	42	14	H19
PM24	1/2	46	16	H22
PM44	1/2	50	16	H22
PM46	3/4	55	18	H32
PM48	1	63	23	H35

암나사 접속용 (PF형)

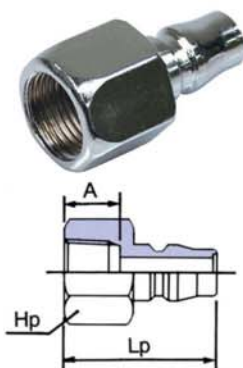

품 명	관접속구경 (R/PT)	치수(mm)		
		Lp	A	Hp
PF22	1/4	36	13	H17
PF23	3/8	37	14	H21
PF24	1/2	38	15	H29
PF44	1/2	41	15	H29
PF46	3/4	45	17	H35
PF48	1	54	22	H41

Ace Coupler

홀(HOLE)

호스 접속용 (SH형)

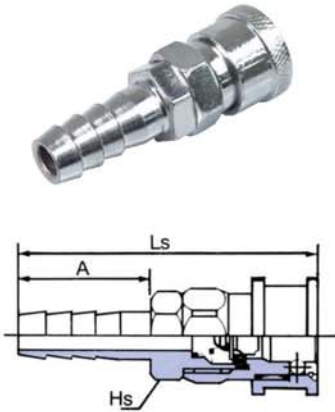

품 명	관접속구경 (호스닛볼)	치수(mm)		
		Ls	A	Hs
SH22	1/4	72.5	30	H19
SH23	3/8	76.5	34	H19
SH24	1/2	78.5	36	H19
SH44	1/2	83.0	36	H29
SH46	3/4	92.0	45	H29
SH48	1	72.0	22	H29

숫나사 접속용 (SM형)

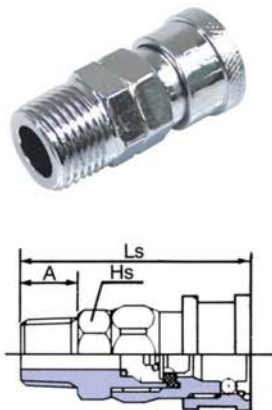

품 명	관접속구경 (R/PT)	치수(mm)		
		Ls	A	Hs
SM22	1/4	55.5	13	H19
SM23	3/8	56.5	14	H19
SM24	1/2	59.5	16	H22
SM44	1/2	63.0	16	H29
SM46	3/4	67.0	19	H32
SM48	1	72.0	22	H36

암나사 접속용 (SF형)

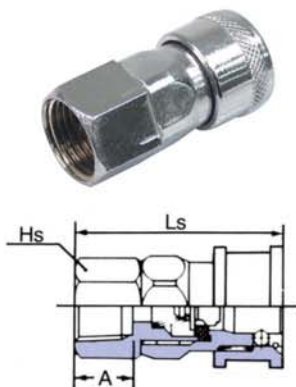

품 명	관접속구경 (R/PT)	치수(mm)		
		Lp	A	Hs
SF22	1/4	49.5	13	H19
SF23	3/8	50.5	14	H21
SF24	1/2	52.5	15	H29
SF44	1/2	57.0	15	H29
SF46	3/4	61.0	17	H35
SF48	1	68.0	22	H41

Nut Coupler

코르크(CORK)·C

우레탄튜브 접속용 (PN형)S-TYPE



품 명	관접속구경 (호스닛볼)
PN22	8Ø
PN23	10Ø
PN24	12Ø

Nut Coupler

코르크(CORK)·C

우레탄튜브 접속용 (SN형) S-TYPE



품 명	관접속구경 (호스닛볼)
SN22	8Ø
SN23	10Ø
SN24	12Ø

Nut Coupler

스프링타입

너트커플러 (SN형)S-TYPE

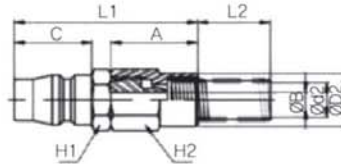

품명	ØD2	Ød2	ØB	L1	L2	A	C	H1	H2	W.G(g)	Q'ty/ Inbox
SN-S22S	14	9.2	4	48.5	53	23	20.5	14	14	29.8	50
SN-S23S	17	11.2	5	53.5	67	27	20.5	17	17	39.2	25
SN-S24S	19	13.2	7	60.5	78	35	20.5	19	19	53.8	25

Nut Coupler

스프링타입

너트커플러 (PN형)S-TYPE

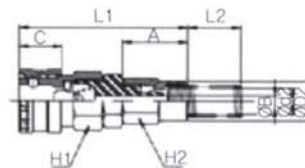

품명	ØD2	Ød2	ØB	L1	L2	A	C	H1	H2	W.G(g)	Q'ty/ Inbox
PN-S22S	14	9.2	4	83	53	23	20.5	14	14	88.7	25
PN-S23S	17	11.2	5	88	67	27	20.5	17	17	97.8	20
PN-S24S	19	13.2	7	05	78	35	20.5	19	19	110.7	20

TSP Coupler

플러그(PLUG)·P

숫나사 접속용 (TPM형)

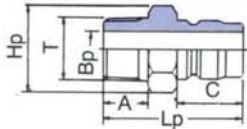

품명	적용관	중량 (g)			치수 (mm)					
		강철	황동	스테인리스	Lp	øHp	A	C	øT(PT)	øBp
1TPM	1/8	16	17	17	32	12	7	15.5	1/8	4.5
2TPM	1/4	30	33	30	38	17	13	18	1/4	6.5
3TPM	3/8	41	45	42	43	19	13	21	3/8	10
4TPM	1/2	81	88	81	52	22	17	24	1/2	13
6TPM	3/4	164	179	165	59	32	19	28	3/4	17
8TPM	1	273	297	274	53	41	22	36	1	25
10TPM	1 1/4	520	560	530	83	50	23	39	1 1/4	32
12TPM	1 1/2	655	765	665	93	54	26	45	1 1/2	38
16TPM	2	1240	1345	1250	102	ø80x2°75	27	41	2	50

암나사 접속용 (TPF형)

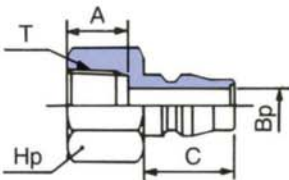

품명	적용관	중량 (g)			치수 (mm)					
		강철	황동	스테인리스	Lp	Hp	A	C	øT(PT)	øBp
1TPF	1/8	14	15	14	26	6°14	9	15.5	1/8	4.5
2TPF	1/4	28	31	29	34	6°17	13	18	1/4	6.5
3TPF	3/8	43	47	43	38	6°21	13	21	3/8	10
4TPF	1/2	103	113	104	45	6°29	17	24	1/2	13
6TPF	3/4	166	181	167	51	6°35	19	28	3/4	17
8TPF	1	321	350	323	60	6°41	22	36	1	26
10TPF	1 1/4	567	615	573	64	2°45xø59	23	38	1 1/4	32
12TPF	1 1/2	703	763	630	77	2°58xø65	25	45	1 1/2	38
16TPF	2	1226	1374	1190	83	2°77xø82	29	51	2	50

TSP Coupler

SOCKET·S

숫나사 접속용 (TSM형)

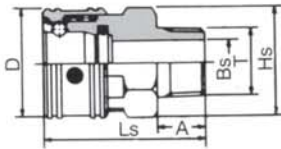

품명	적용관 (PT)	중량 (g)			치수 (mm)					
		강철	황동	스테인리스	Ls	øD	Hs	A	T(PT)	øBs
1TSM	1/8	25	27	26	30	17.5	6角14	9	1/8	4.5
2TSM	1/4	66	72	67	42	24	6角19	13	1/4	7
3TSM	3/8	99	108	100	46	28	6角23	13	3/8	10
4TSM	1/2	178	194	179	56	35	6角29	17	1/2	13
6TSM	3/4	343	374	346	65	45	6角38	19	3/4	18
8TSM	1	629	685	633	76	58	6角50	22	1	24
10TSM	1 1/4	950	1025	955	86	69	2角54xø62	25	1 1/4	32
12TSM	1 1/2	1160	1245	1180	95	75	2角58xø66	25	1 1/2	38
16TSM	2	1990	2110	2000	108	95	6角77xø82	29	2	49

암나사 접속용 (TSF형)

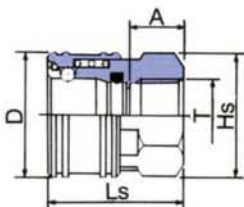

품명	적용관 (PT)	중량 (g)			치수 (mm)					
		강철	황동	스테인리스	Ls	øD	Hs	A	T(PT)	
1TSF	1/8	25	27	25	27	17.5	6角14	9	1/8	
2TSF	1/4	57	62	57	32	24	6角19	13	1/4	
3TSF	3/8	83	90	83	35	28	6角23	13	3/8	
4TSF	1/2	153	167	154	42	35	6角29	17	1/2	
6TSF	3/4	288	314	289	48	45	6角38	19	3/4	
8TSF	1	557	607	561	59	58	6角50	22	1	
10TSF	1 1/4	821	888	815	64	69	2角54xø62	23	1 1/4	
12TSF	1 1/2	1003	980	1003	71	75	2角58xø66	25	1 1/2	
16TSF	2	1726	1675	1732	80	95	2角77xø82	27	2	

SP Coupler

적용	적용유체	용도
황동	가솔린·중유·경유·물·공기	· 배수관·해수 · 산·아세치렌 · 스티배관 · 화학약품·화학프런트 · 고압가스(철소·후레온 등)
스테인레스	산·알칼리·염수	
강철	작동유	

본체재질	황동				스테인레스·강철(흑염처리)			
	1/8-3/4 3/8	1 1/2-3/4	1 1/4 1 1/2	2	1/8-1/4 3/8	1/2-1/4 1	1 1/4 1 1/2	2
규격								
상용압력(kg/cm ²)	50	30	20	15	75	45	30	20
최고압력(kg/cm ²)	75	45	30	23	100	65	45	30
패킹재질 사용온도범위	고무재질			사용온도 범위		표준재질		
	니트릴고무			-20℃ ~ +80℃		표준재질		
	바이톤			-20℃ ~ +180℃		준표준품		
	네온후렌			-20℃ ~ +80℃				
	예치푸로피렌고무렌			-40℃ ~ +150℃				
접속현황	소켓트·프러그 전체 F (암나사)							

플러그 (PLUG) · SP-P

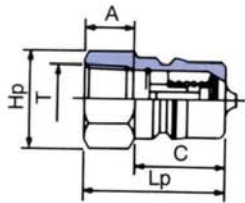

품명	적용관 (PT)	중량 (g)			치수 (mm)					
		강철	황동	스테인레스	Lp	C	A	Hp	T(PT)	
1P	1/8	19	21	19	29	19	11	6角14	1/8	
2P	1/4	35	38	35	36	22	13	6角17	1/4	
3P	3/8	60	65	60	40	25	13	6角21	3/8	
4P	1/2	123	134	124	44	28	15	6角29	1/2	
6P	3/4	212	231	213	52	36	17	6角35	3/4	
8P	1	350	381	352	62	40	20	6角41	1	
10P	1 1/4	592	645	596	70	45	2	2角54xø59	1 1/4	
12P	1 1/2	889	968	895	75	49	24	2角63xø69	1 1/2	
16P	2	1503	1637	1512	80	52	27	2角77xø84	2	

소켓트 (SOCKET) · SP-S

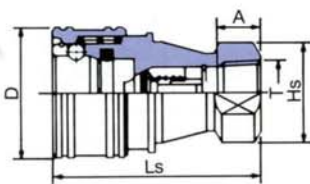

품명	적용관 (PT)	중량 (g)			치수 (mm)					
		강철	황동	스테인레스	Ls	øD	A	Hs	T(PT)	
1S	1/8	85	93	86	48	24	11	2角14xø18	1/8	
2S	1/4	133	145	134	58	28	13	2角19xø22	1/4	
3S	3/8	208	227	209	65	35	13	2角21xø25	3/8	
4S	1/2	428	466	431	72	45	15	2角29xø35	1/2	
6S	3/4	710	773	714	88	55	17	2角35xø41	3/4	
8S	1	1000	1089	1006	102	65	20	2角41xø48	1	
10S	1 1/4	1587	1728	1596	115	77.5	24	2角54xø59	1 1/4	
12S	1 1/2	2330	2537	2345	124	87.5	24	2角63xø69	1 1/2	
16S	2	3645	3969	3668	132	10.9	27	2角77xø86	2	

HSP Coupler (유압카플러)

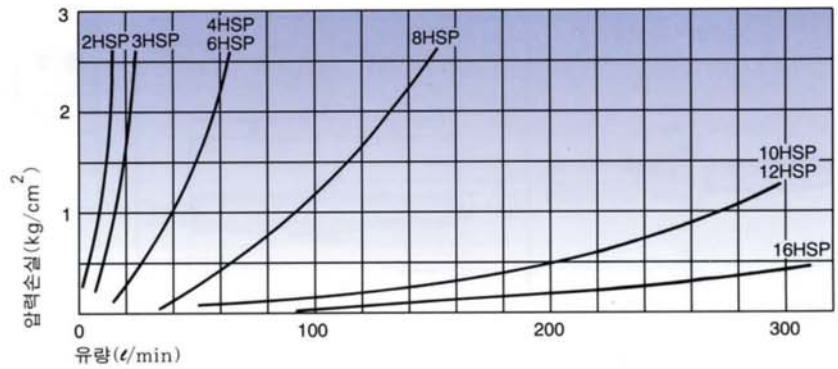

플러그 (PLUG) · HP

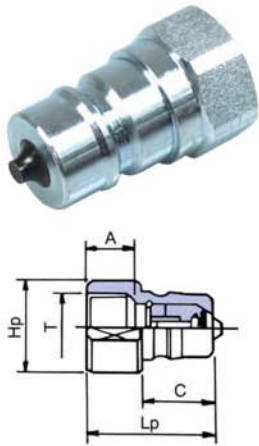

품 명	적용관 (PT)	중 량 (g)	치 수 (mm)					
			Lp	C	H	Hp	A	T(PT)
2HP	1/4	44	32	17.5	6角19x	∅22	12	1/4
3HP	3/8	72	38	22.5	6角23x	∅25	13	3/8
4HP	1/2	138	44	27.5	6角29x	∅33	16	1/2
6HP	3/4	145	50	27.5	6角32x	∅35	18	3/4
8HP	1	332	61	36	6角41x	∅47	23	1
10HP	1 1/4	894	80	58	6角58x	∅64	24	1 1/4
12HP	1 1/2	596	80	58	6角58x	∅64	24	1 1/2
16HP	2	1513	115	83	6角90x	∅100	32	2

소켓 (SOCKET) · HS

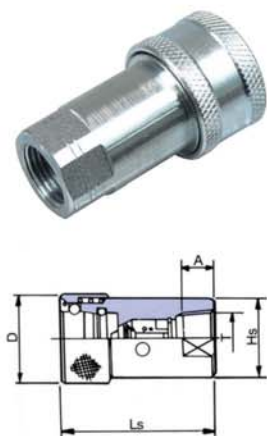

품 명	적용관 (PT)	중 량 (g)	치 수 (mm)					
			Ls	∅D	Hs	A	T(PT)	
2HS	1/4	136	49	27.5	2角19x	∅23.9	12	1/4
3HS	3/8	220	60	33	2角35x	∅28.6	13	3/8
4HS	1/2	482	72	43	2角35x	∅38.5	16	1/2
6HS	3/4	452	72	43	2角35x	∅38.5	18	3/4
8HS	1	1020	93	58	2角46x	∅52.2	20	1
10HS	1 1/4	2344	138	87	2角58x	∅64	24	1 3/4
12HS	1 1/2	1597	138	87	2角58x	∅64	24	1 1/2
16HS	2	3699	198	128	2角80x	∅90	32	2

YM NIPPLE

Seamless Tube

Copper Tube

Seamless Steel Tube

Outside diameter		Wall thickness	Inside diameter		Flow cross section	Weight
Nominal size	Permissible deviation	Nominal size	Nominal size	Permissible deviation	-cm ²	kg/m
mm	mm	mm	mm	mm		
4	±0.075	1	2	±0.15	0.031	0.074
6	±0.075	1	4	±0.12	0.13	0.123
6		1.5	3	±0.15	0.071	0.166
8	±0.075	1	6	±0.10	0.28	0.173
8		1.5	5	±0.15	0.20	0.240
10	±0.075	1	8	±0.075	0.50	0.222
10		1.5	7	±0.12	0.38	0.314
10	±0.08	2.5	5	±0.35	0.20	0.462
12	±0.075	1	10	±0.075	0.79	0.271
12		1.5	9	±0.10	0.64	0.389
14	±0.075	1.5	11	±0.075	0.95	0.462
15	±0.075	1.5	12	±0.075	1.13	0.499
15		2	11	±0.10	0.95	0.641
16	±0.075	1.5	13	±0.075	1.33	0.536
16		2	12	±0.075	1.13	0.691
18	±0.075	1.5	15	±0.075	1.77	0.610
18		2	14	±0.075	1.54	0.789
20	±0.075	1.5	17	±0.075	2.27	0.684
20		2	16	±0.075	2.01	0.888
20	±0.08	2.5	15	±0.15	1.77	1.08

Outside diameter		Wall thickness	Inside diameter		Flow cross section	Weight
Nominal size	Permissible deviation	Nominal size	Nominal size	Permissible deviation	-cm ²	kg/m
mm	mm	mm	mm	mm		
22	±0.075	1.5	19	±0.075	2.84	0.758
22		2	18	±0.075	2.55	0.986
25	±0.08	2	21	±0.08	3.46	1.13
25		2.5	20	±0.08	3.14	1.39
25		3	19	±0.15	2.84	1.63
28	±0.08	1.5	25	±0.08	4.91	0.980
28		2	24	±0.08	4.52	1.28
28		3	22	±0.15	3.80	1.85
30	±0.08	2	26	±0.08	5.31	1.38
30		2.5	25	±0.08	4.91	1.70
30		3	24	±0.15	4.52	2.00
30		4	22	±0.15	3.80	2.57
30		5	20	±0.15	3.14	3.08
35	±0.15	2	31	±0.15	7.55	1.63
35		3	29	±0.15	6.61	2.37
35		4	27	±0.15	5.73	3.06
35		5	25	±0.15	4.91	3.70
38	±0.15	2.5	33	±0.15	8.55	2.19
38		3	32	±0.15	8.04	2.59
38		4	30	±0.15	7.07	3.35
38		5	28	±0.15	6.16	4.07
42	±0.20	2	38	±0.20	11.34	1.97
42		3	36	±0.20	10.18	2.89
42		4	34	±0.20	9.08	3.75
50	±0.20	4	42	±0.20	13.85	4.54
50		5	40	±0.20	12.57	5.55
50		6	38	±0.20	11.34	6.51
50		8	34	±0.20	9.08	8.29
50		10	30	±0.20	7.07	9.87

Copper Tube

	0.5	0.6	0.7	0.8	0.9	1.0	1.1	1.2	1.4	1.5	1.6
3.17	○	○									
4.00	○	○									
4.76	○	○									
6.00		○	○	○	○	○					
6.35		○	○	○	○	○					
8.00		○	○	○	○	○					
9.52			○	○	○	○					
10.00				○	○	○	○	○			
12.00					○	○	○	○		○	
12.70					○	○	○	○			
15.00					○	○	○	○			
15.88					○	○	○	○			
19.05						○	○	○	○	○	
22.22								○	○	○	○
25.40								○	○	○	○

Ball Valves

2-Way Ball Valves
Hyd's Ball Valves
Stainless Ball Valves



2-Way Ball Valves(Brass)

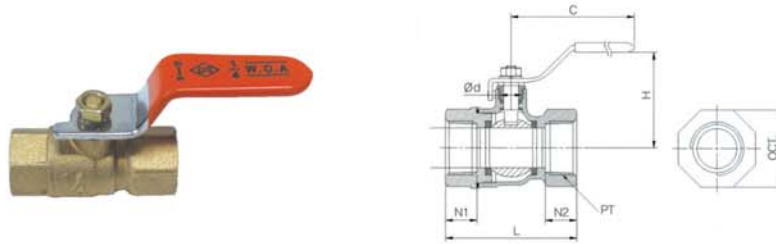

규격	ØD	Ød	C	H	N1	N2	L	PT	Oct.	Q'ty/ Inbox
8A(1/4")	8	7	71	32	10.6	10.6	42	R1/4	20	20
10A(3/8")	8	7	68	32	14	12.3	44	R3/8	20	20
15A(1/2")	10	8	90	42	14.5	13	50.5	R1/2	24	20
20A(3/4")	15	9	90	45	17	14	56.5	R3/4	30	20
25A(1")	20	11	104	55	16.5	16.2	67	R1	37	10
32A(1" 1/4)	25	11	103	63.5	19	19	79	R1 1/4	47	6
40A(1" 1/2)	32	15	140	67	20	20	88.5	R1 1/2	53	4
50A(2")	40	15	160	74.5	21.3	20.5	100	R2	66	4
65A(2" 1/2)	50	18	170	90.5	26.4	26.4	127.5	R2 1/2	83	2
80A(3")	65	21	170	101	28	28	143.8	R3	98	1
100A(4")	80	21	223	105	38.5	38.5	187.5	R4	122	1

Hyd's Ball Valves(Steel, Stainless Steel)

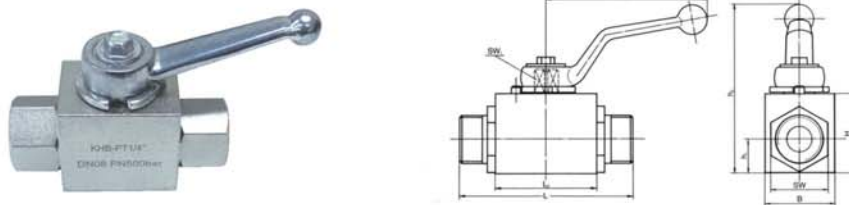

규격	8A(1/4")	10A(3/8")	15A(1/2")	20A(3/4")	25A(1")	32A1(1/4")	40A1(1/2")	50A(2")

Stainless Ball Valves

1PC

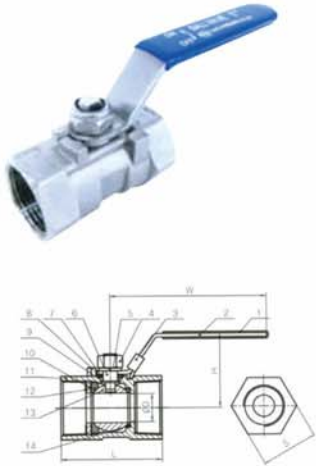

품명	ØD	L	H	W	S	W.G(g)	Q'th/ Inbox
1/4(8A)-1PC	5	39.5	31	67	17	71	20
3/8(10A)-1PC	6.8	43.5	34	87	20.5	109	15
1/2(15A)-1PC	9.2	57	39	96	25	180	10
3/4(20A)-1PC	12.5	59	44	96	31.5	260	8
1 (25A)-1PC	15	71	48	112	37.5	425	5
1-1/4(32A)-1PC	20	78	54	112	47	640	4
1-1/2(40A)-1PC	25	82.5	60	142	52	792	4
2 (50A)-1PC	32	99	66	142	64	1227	2

Stainless Ball Valves-N Type

1PC



품명	ØD	L	W	S	W.G(g)	Q'th/ Inbox
N 1/4(8A)-1PC	5	39.5	42	17	54	25
N 3/8(10A)-1PC	6.8	43.5	43	20.5	90	25
N 1/2(15A)-1PC	9.2	57	58	25	151	15
N 3/4(20A)-1PC	12.5	59	58	31.5	215	10
N 1 (25A)-1PC	15	71	71	37.5	391	5
N 1-1/4(32A)-1PC	20	78	71	47	613	4
N 1-1/2(40A)-1PC	25	82.5	84	52	696	3
N 2 (50A)-1PC	32	99	84	64	1169	2

Stainless Ball Valves

2PC



품명	128L ±2.0	ØD	H	W	T	S	W.G(g)	Q'th/ Inbox
1/4(8A)-2PC	50	6	43	79	1.4	19	129	15
3/8(10A)-2PC	50	8	43	79	1.6	21	125	10
1/2(15A)-2PC	58	10	48	106	2	25	196	8
3/4(20A)-2PC	65	15	50	116	2	30	266	5
1 (25A)-2PC	78	20	61	123	2	37.6	436	4
1-1/4(32A)-2PC	88	25	69	123	2.3	47	638	4
1-1/2(40A)-2PC	96	32	78	153	2.6	53	988	2
2 (50A)-2PC	112	40	85	153	3	65.6	1515	2
2-1/2(65A)-2PC	128	50	92	196	3.5	82	2529	2

Incn Mm 환산 및 규격표

INCH (寸)	mm	동관 외경	강관 외경	가스관용나사			UNF 세목적용나사			NPT America 관용나사		호스 내경
		mm	mm	나사 선수	외나사 기본외경	내나사 기본외경	나사 선수	내나사 기본외경	외나사 기본외경	나사 선수	외나사 기본외경	모
1/8	3.175	3.17	(6A) 10.5	28	9.728	8.566				27	10.160	
3/16	4.763	4.8									13.427	4.8
1/4	6.350	6.35	8(A) 13.8	19	13.157	11.445	28	6.350	5.367	18	13.427	6.3
5/16	7.938	8.00					24	7.938	6.792			7.9
3/8	9.525	9.52	(10A) 17.3	19	16.662	14.905	24	9.525	8.379	18	16.866	9.5
7/16	11.112						20	11.112	9.738			
1/2	12.700	12.70	(15A) 21.7	14	20.955	18.631	20	12.700	11.326	14	20.980	12.7
5/8	15.875	15.88		14	22.911	20.587	18	15.875	14.442			15.9
3/4	19.050	19.05	(20A) 27.2	14	26.441	24.117	16	19.050	17.330	14	26.326	19.0
7/8	22.225	22.22		14	30.201	27.877	14	22.225	20.262			
1	25.400	25.40	(25A) 34.0	11	33.249	30.291	12	25.400	23.109	11 1/2	32.932	25.4
1 1/8	28.575	28.58		11	37.897	34.939	12	28.575	26.284			
1 1/4	31.750	31.75	(32A) 42.7	11	41.910	38.952	12	31.750	29.459	11 1/2	41.689	31.8
1 3/8	34.925	34.93					12	34.925	32.634			
1 1/2	38.100	38.10	(40A) 48.6	11	47.803	44.845	12	38.100	35.809	11 1/2	47.758	38.1
1 3/4	44.450	44.45		11	53.788	50.788						44.5
2	50.800	50.80	(50A) 60.5	11	59.614	56.656				11 1/2	59.796	50.8
2 1/4	57.150			11	65.710	62.752				8		57.1
2 1/2	63.500	63.50	(65A) 76.3	11	75.184	72.226				8	72.273	63.5
3	76.200	76.20	(80A) 89.1	11	87.884	84.926				8	88.182	76.2
3 1/2	88.900	88.90	(90A) 101.6	11	100.330	97.372				8	100.891	88.9
4	101.600	101.60	(100A) 114.3	11	113.030	110.072				8	113.548	101.6
5	127.000	127.00	(125A) 139.8	11	138.430	135.472						



여명닛불상사

부산광역시 사상구 과감로14(감전동)

TEL : (051) 328-2018 (代)

FAX : (051) 316-0340

공장 : (051) 328-2019

E-mail : ymnipple@naver.com

www.ymnipple.com